

DC INVERTER VRF SYSTEM

Product Catalogue



ABOUT MAMMOTH

Since 1935, Mammoth has been producing and installing air conditioning units with the most innovative technologies. Our solutions are found in some of the world's most important buildings for its unparalleled flexibility and efficiency. When performance and energy efficiency are important factors to a project, our products are often chosen as the final solution.

Established in Minneapolis, USA - 1935

Since 1935, Mammoth has been producing and installing air conditioning units with the most innovative technologies. Our solutions are found in some of the world's most important buildings for its unparalleled flexibility and efficiency. When performance and energy efficiency are important factors to a project, our products are often chosen as the final solution.

Energy Saving & Innovation

Mammoth produces air conditioning equipment that leverages energy saving and innovative technologies. Our products include, but not limited to, geothermal & water source heat pumps, air & water cooled commercial air conditioning units, fan coils, AHU, VAV box, screw chillers, and energy recovery units.

Customization & Energy Saving is Our Standard

Mammoth has been recognized as a leader in providing custom designed Total Energy Solution HVAC Systems. Our solutions can fit any design applications from WSHP systems to geothermal systems, from hybrid systems to various energy saving systems. Based on the needs of our customers, our recommendations help our customers assess the economic benefits of Mammoth solutions over alternative systems.

Outstanding Achievement

Mammoth has also brought its innovative design concepts to the industry. We have printed numerous technical design manuals and books to facilitate engineers in the design of Renewable Energy HVAC Systems. Together with industry associations and the commercial section of the US Embassy and Consulate General Offices, we have frequently conducted technical seminars in major cities in China and abroad. We have supplied our solutions to projects that amount to almost 10 million sq. m., and have been continuously recognized as the leader in Renewable Energy products in China.



Production Capacity

Our factory has 17 advanced production lines and an annual production capacity of over 1.5 million sets. Introduce lean production management, improves production efficiency. By using various robots, AGV systems and other equipment, improve online and offline processes, optimize logistics and distribution technology, and improve product quality and production efficiency. The use of MES system helps to track production progress, inventory status, work progress and other operational management, and improve product quality and production efficiency.



Quality Superiority



We have established a strict and scientific quality management system with supplier quality assurance, incoming quality control, process quality control and final quality control to ensure the quality of the products.

The testing center has been certified by CNAS in 2018, with a full range of professional incoming inspection labs, enthalpy difference labs, EMC labs, 42 national accredited labs for testing and verification.

Certification

The R&D center has more than 200 technical engineers, carries out technology collaboration and joint research with postdoctoral research workstations, at the same time, introducing senior technical experts from Japan join us to develop new technology, by the continuous innovation, we have established a solid development foundation and strength in performance, structure, electronic control, industrial design and other professional aspects.

The test center covers an area of more than 15,000 square meters. It has a series of professional laboratories. In 2010, it passed the consistency check of the National Energy Efficiency Label Management Center and obtained certificate, in 2018, the test center obtained CNAS national certification.





How To Read The Model Name

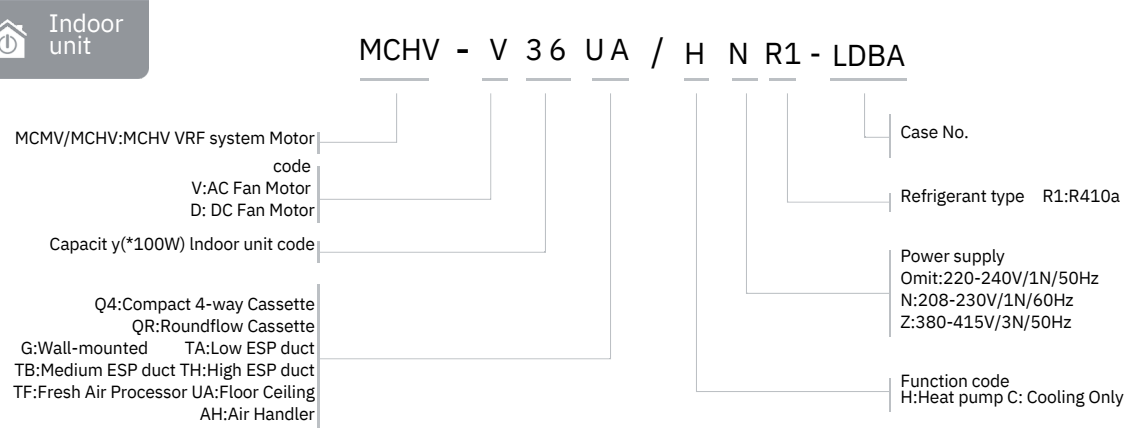
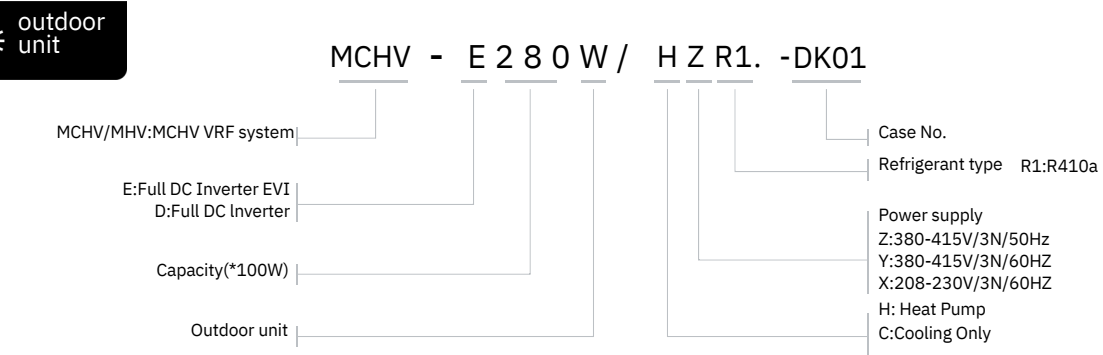

8/10/12HP



14/16HP



18/20HP



22HP



24HP



26/28/30/32HP

13 Basic Modules

Capacity	8HP	10HP	12HP	14HP	16HP	18HP	20HP	22HP	24HP	26HP	28HP	30HP	32HP
	25.2kW	28kW	33.5kW	40kW	45kW	50kW	56kW	61.5kW	67kW	73kW	78.5kW	85kW	90kW
Compressor	DC	DC	DC	DC	DC	DC	DC	DC	DC+DC	DC+DC	DC+DC	DC+DC	DC+DC
Fan motor	DC	DC	DC	DC	DC	DC+DC	DC+DC	DC+DC	DC+DC	DC+DC	DC+DC	DC+DC	DC+DC

EER & COP

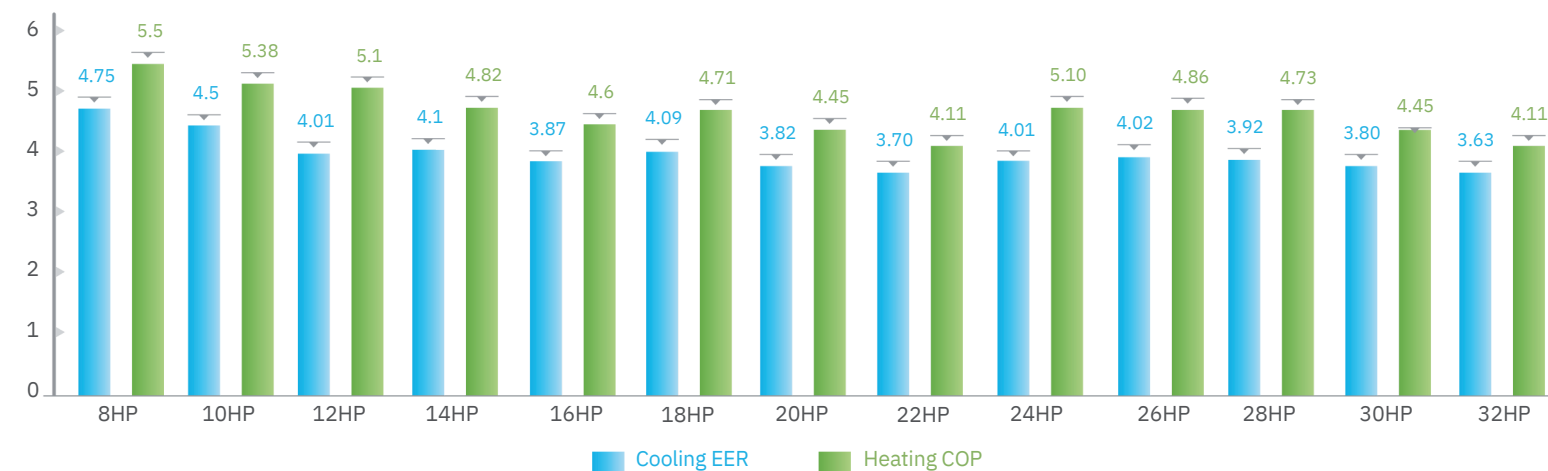

FEATURES

Combination Table

HP	Cooling Cap.(kW)	8HP	10HP	12HP	14HP	16HP	18HP	20HP	22HP	24HP	26HP	28HP	30HP	32HP
8	25.2	●												
10	28		●											
12	33.5			●										
14	40				●									
16	45					●								
18	50						●							
20	56							●						
22	61.5								●					
24	67									●				
26	73										●			
28	78.5											●		
30	85												●	
32	90													●
34	95					●	●							
36	100						●	●						
38	106.5					●		●	●					
40	111.5						●		●	●				
42	117.5							●		●	●			
44	123								●	●	●			
46	128.5									●	●	●		
48	134										●	●		
50	140											●	●	
52	145.5												●	●
54	152													●
56	157													●
58	163													●
60	168.5													●
62	175													●
64	180													●
66	184.5													●
68	190													●
70	195.5													●
72	201.5													●
74	207													●
76	212.5													●
78	218.5													●
80	224													●
82	230													●
84	235.5													●
86	242													●
88	247													●
90	253													●
92	258.5													●
94	265													●
96	270													●

*Note:Max.4 outdoor units can be freely combined to become a larger unit, the maximum capacity of single system is 96HP, when 4 outdoor units are combined, the single unit capacity can not exceed 24HP.

Long Refrigerant Piping

The total pipe length	1000 m
The longest pipe length	200 /240m Outdoor unit
Height difference	above <100m Outdoor unit below <110m
Height difference between indoor units	40m
Length from first indoor distributor to last indoor unit	90 m
Communication wire length	can be up to 1000m.

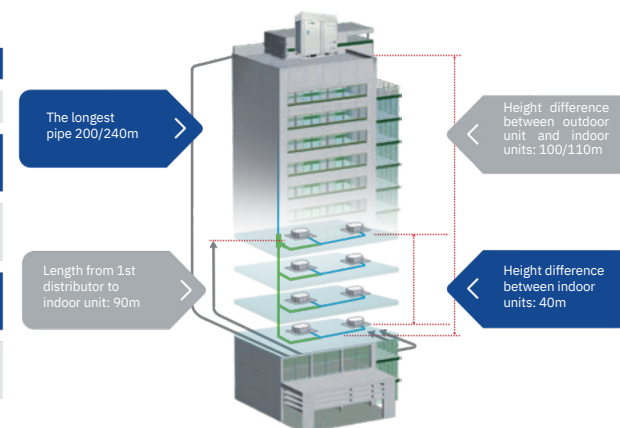

*Please refer to the installation manual for detailed length description.

FEATURES

Long Distance Remote Control

Long distance remote control by phone or tablet.

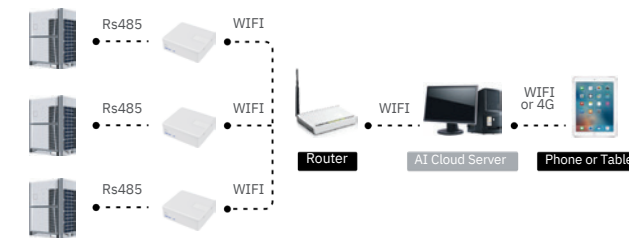

Malfunction Forecasting

Thanks to the AI cloud server, malfunction can be forecasted when system running parameter is abnormal. Technician can be sent to site to check the system before it stops.

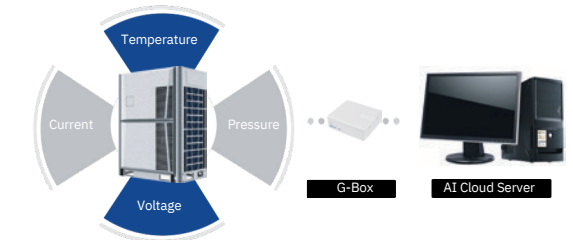

Refrigerant Cooling Design

We use refrigerant to cool down inverter modular board to keep it in a safe condition even when outdoor temperature is up to 55°C.



Wide Outdoor Operation Range

Due to EVI technology, MCHV PRO still has 85% of rated capacity even in -15°C.

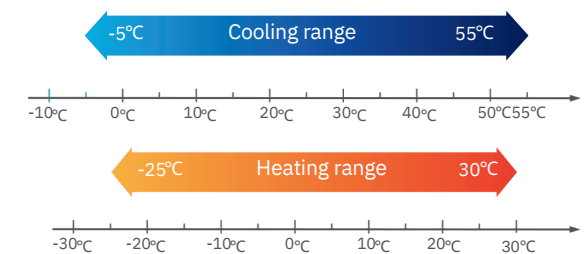

*Based on GCHV internal test report

Power Saving Mode

According to power usage, realize 7-level power limit setting.

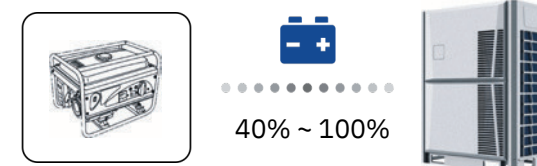

Refrigerant Status Detection

Built-in with smart refrigerant auto check function, which can give suggestion about refrigerant status. Different code means different refrigerant status:

13	Extremely insufficient
12	Insufficient
11	Slightly insufficient
0	Normal
1	Slightly excess
2	Overmuch

FEATURES

② More indoor units

Max.100 Indoor units can be connect in ONE system.

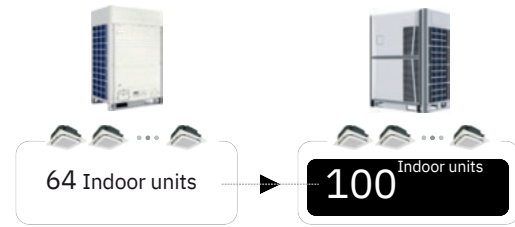

🔒 Electrical Lock Function(optional)



In case of end user doesn't pay as contract, electrical lock function can be used to stop VRF system, and end user can not start the system without permission. System can be unlock with password by authorized technician.

📶 Wireless Communication(optional)

Wireless communication between indoor units. Wireless communication between indoor unit and outdoor unit.

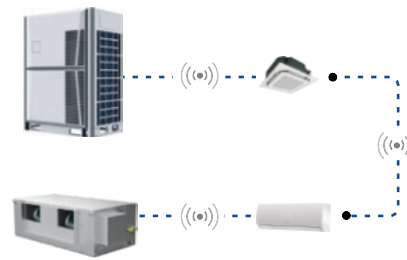

🩺 Online Diagnosis

Technician can do the commissioning & diagnosis by phone or tablet online.

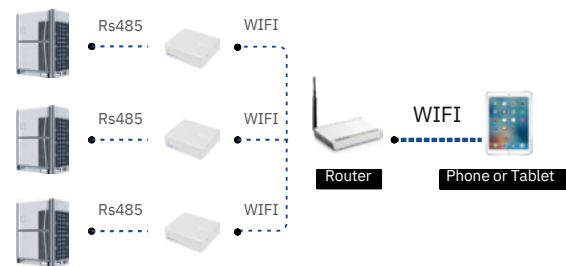

👉 Service Window On Front Cover

Thanks to the service window, checking outdoor units status and setting is now easy, no need to remove the front cover.

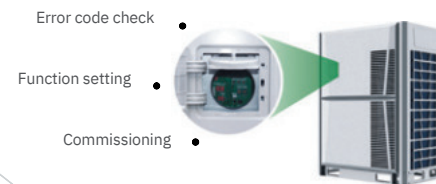

🔧 Auto Charging Refrigerant(optional)

CHV PRO can customize with auto refrigerant charging function, additional solenoid valve will be added in gas pipe, and outdoor unit will control the valve to charge refrigerant.

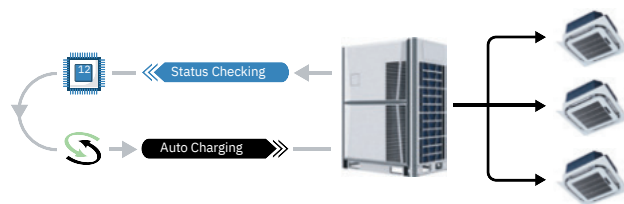

🏠 13 Basic Modules



🏠 Maximum 96HP



Max.3 outdoor units can be freely combined to become a larger unit. the maximum capacity of single system is 96HP. *:when 4 outdoor units are combined, the single unit capacity can not exceed 24HP.

1 High Efficiency

2 Benefits For Users

3 Benefits For Installers

Advantages

Provide You With Fresh Air

1

High Efficiency

Low carbon life advocate

We always focus on low-carbon energy-saving products development, and spare no effort for technological research and development, to become a practitioner and advocate of low-carbon technology!

Core Technologies Make High Efficiency

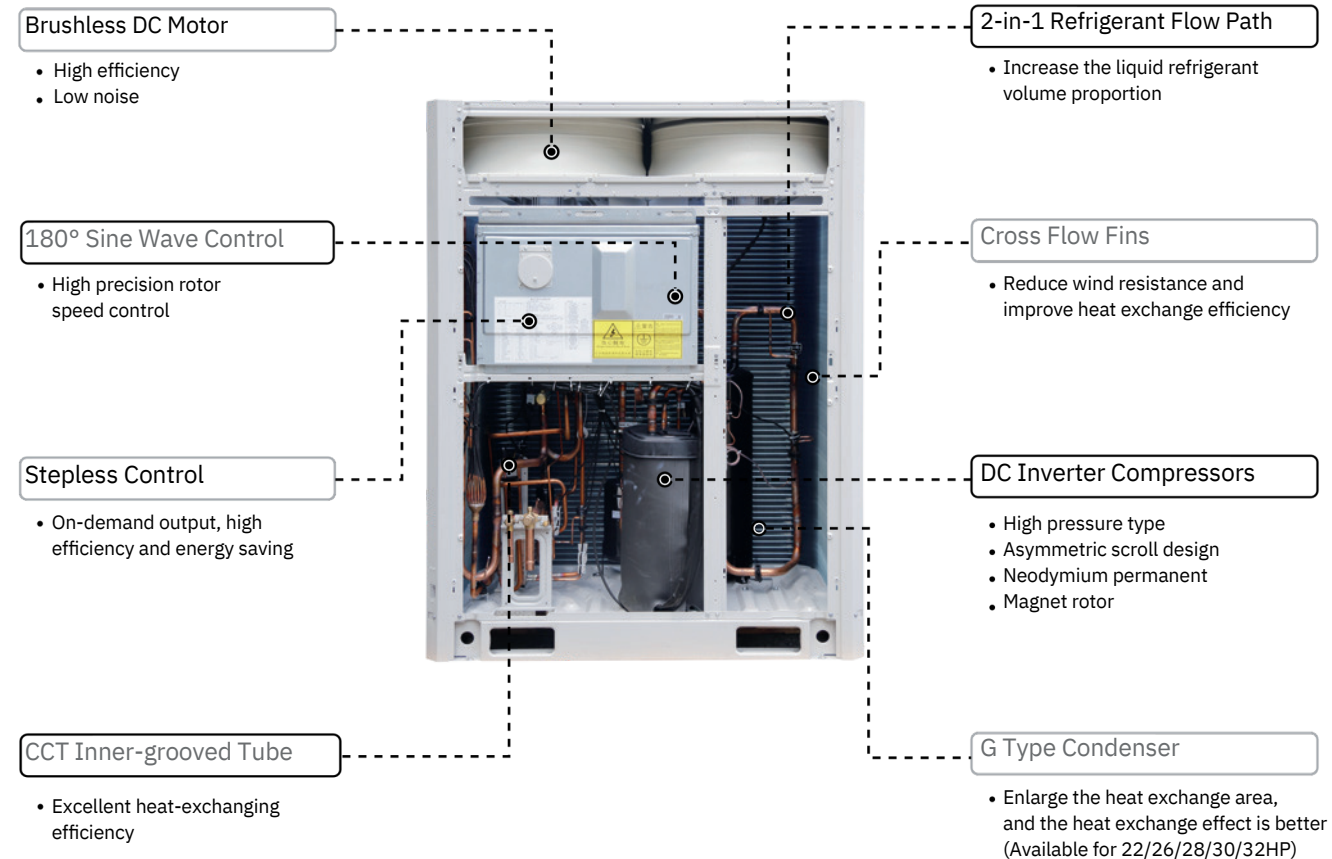

High Efficiency DC Inverter Compressor

- From Hitachi, famous inverter compressor manufacturer.
- R410a environmentally balanced refrigerant.
- Small torque fluctuation, low vibration and quiet operation.
- High efficiency due to its internal structure design.
- Internal oil circulation structure.
- High reliability.
- Wide rotation speed range.
- Neodymium permanent magnet rotor, has powerful magnetic force, large torque and high efficiency.
- Concentrated winding, improving low frequency efficiency.
- High pressure chamber
 - Has small suction superheat and high refrigerant volume efficiency

Oil balance design, pump extra oil to other compressor.

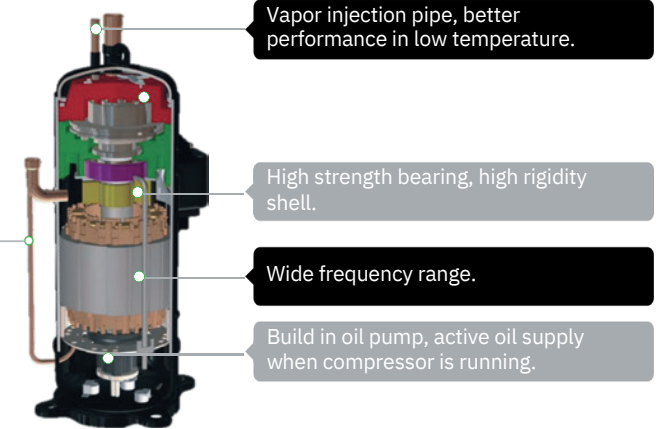

• Has large refrigerant discharge buffer volume, low vibration and noise

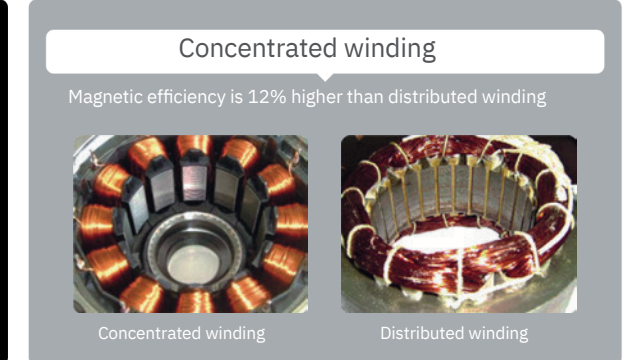
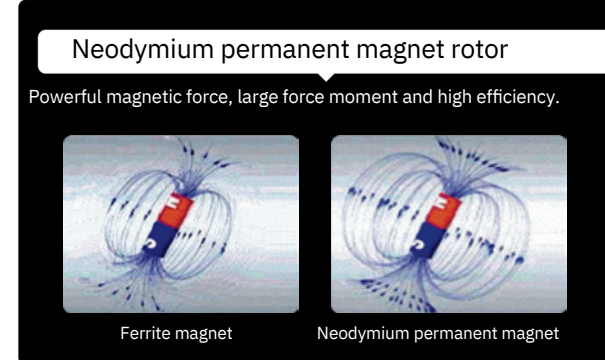

High Efficiency DC Motor

- High efficiency DC fan motor is from well-known brand.
- Low noise and high efficiency because of high-density wire winding engineering.
- Brushless with built-in sensor.

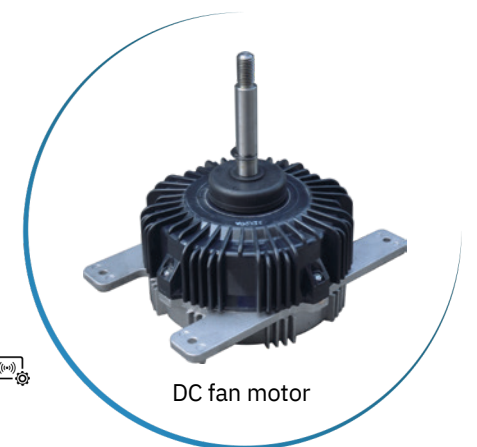

Stepless Control

DC fan motor can be stepless controlled by outdoor PCB according to system's operating pressure, and it is able to reduce the energy consumption and maintain the system in good condition.

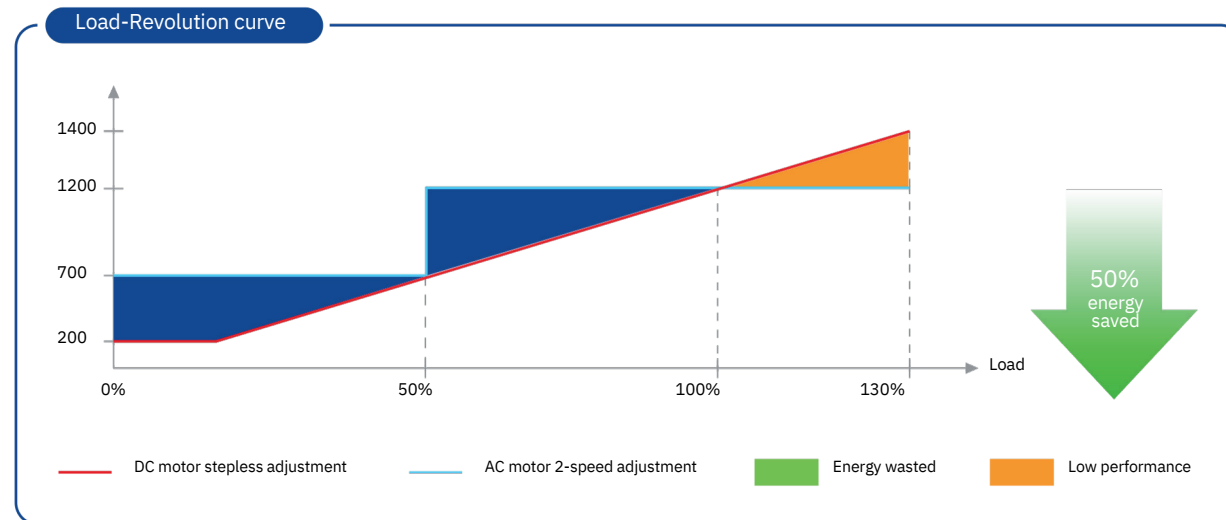

CCT Inner-grooved Tube

CCT (Continuous Cooling Transformation) inner-grooved copper tube has high thermometric conductivity. This inner-grooved fins break the refrigerant flow boundary layer to enhance refrigerant disturbance to increase heat-exchanging efficiency.

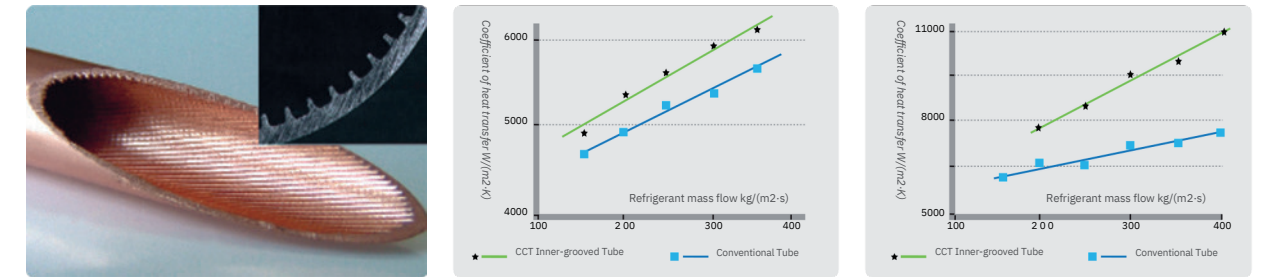

2-in-1 Refrigerant Flow Path Design

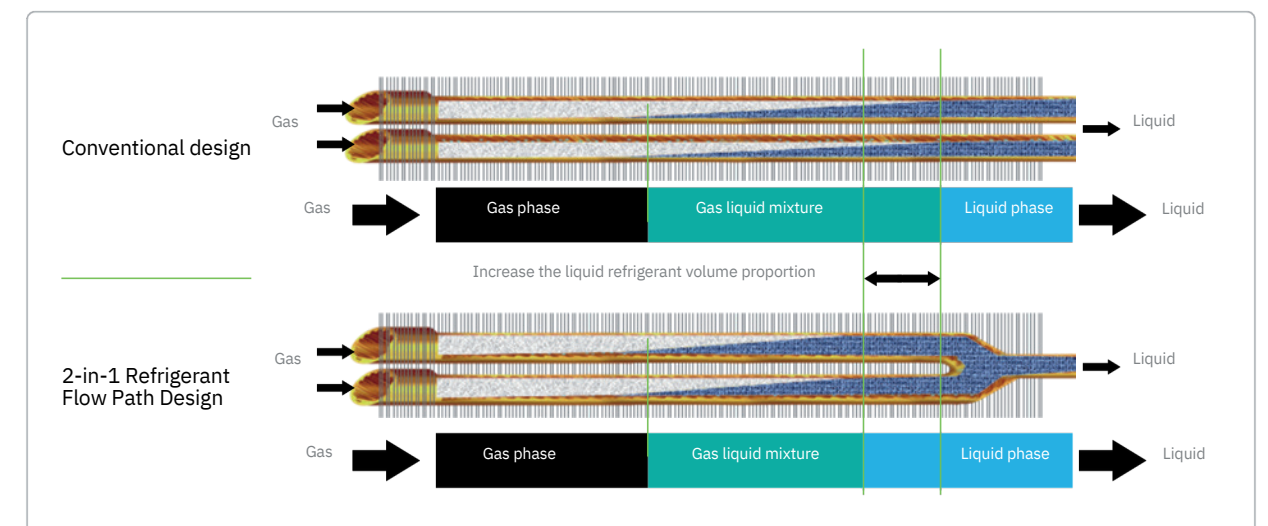
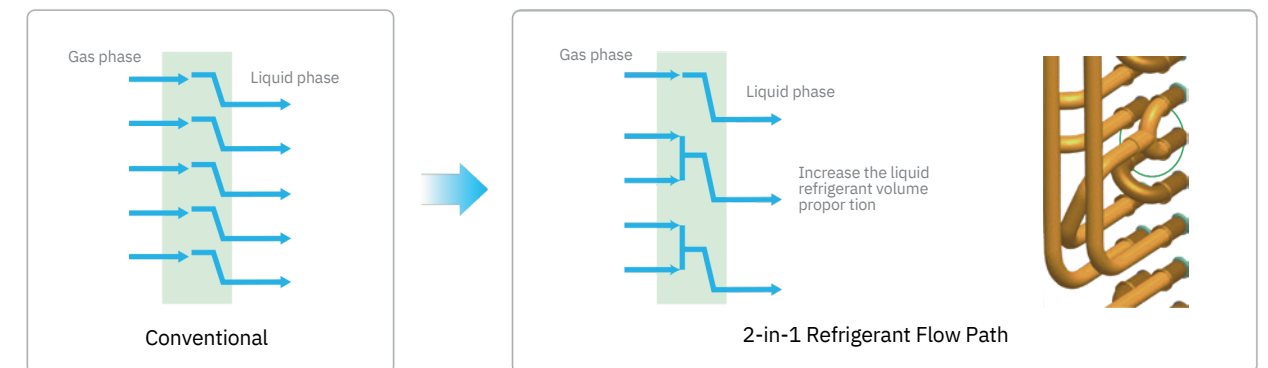

180° Sine Waveform Control

The perfect combination of 180° Sine waveform rotor frequency drive control technology and excellent IPM inverters, reduces the reactive loss of motor-driven, increases motor efficiency by 12%.

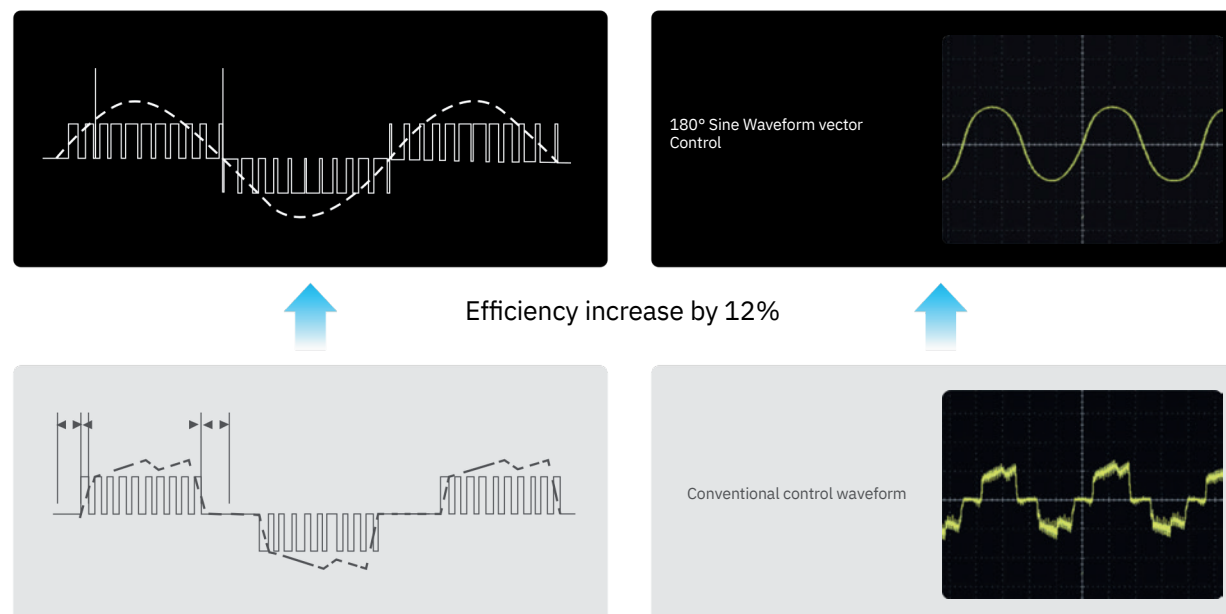

Supercooling Flow Path Design

Supercooling flow path design, separates the refrigerant inlet and outlet, increase the supercooling degree, reduce the effect of high temperature inlet gas refrigerant to low temperature outlet liquid refrigerant, therefore, the system efficiency will be greatly increased.

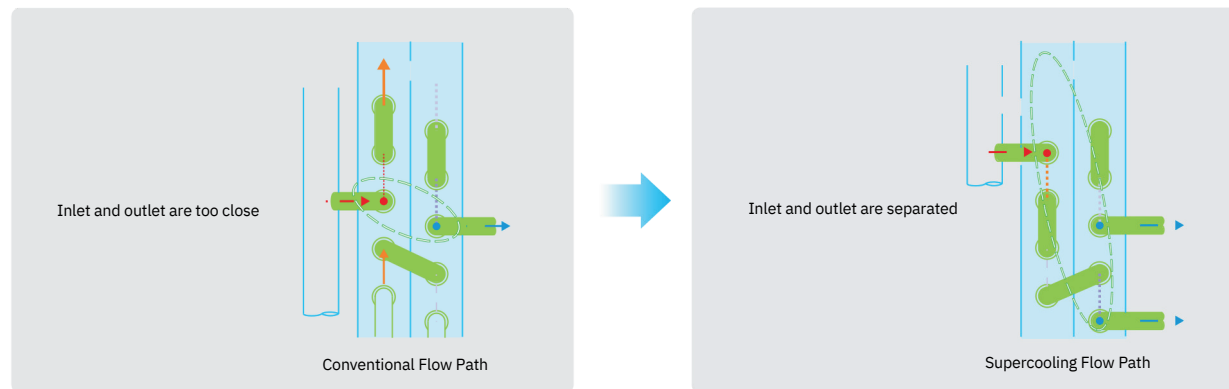

Cross Flow Fins

- Has low air resistance and great heat transfer coefficient. Frosting improved, frost on the heat-exchanger will be well-distributed, easy for defrosting.

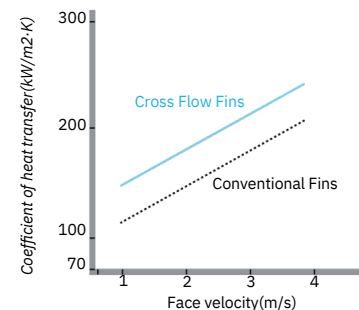
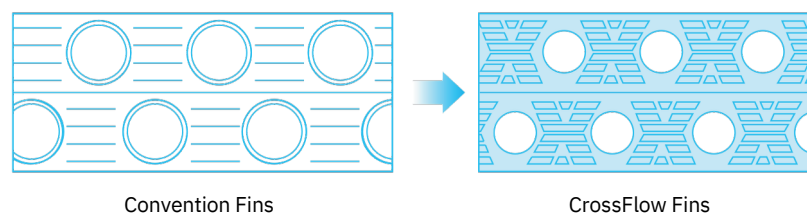

Low Resistance Internal Piping

- Thanks to the optimization pipeline design, 5% pressure drop are reduced. EER and COP increase, because of evaporating temperature increase and compressor work decrease.

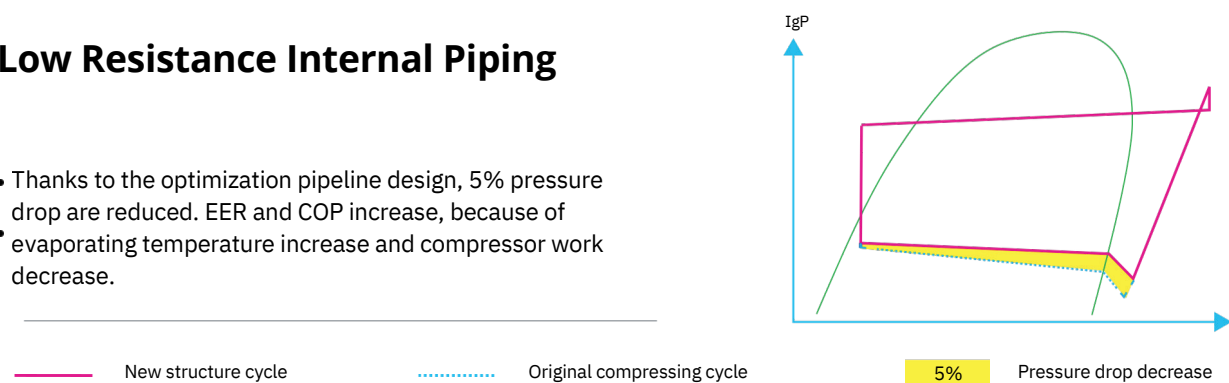
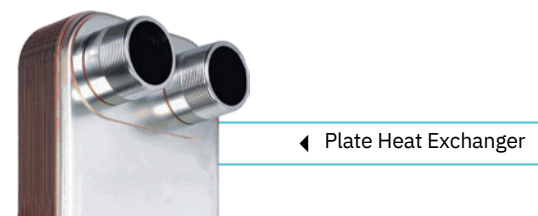

Plate Heat Exchanger

- Provides an additional sub cooling.
- Improved heat exchanger+Plate Heat Exchanger+Optimized control logic.
- Heating performance highly increased.



Benefits For Users

2

Livable environment provider

We focus on starting point of CAC system: provide a friendly, comfortable and pleasant living environment as always. DC inverter VRF system's comfort technologies include quick cooling and heating, precise temperature control, low noise, use environmental balanced refrigerant and so on, we strive to provide livable environment for users.....



Outstanding Comfort Ability

- MCHV Pro VRF system have excellent cooling & heating performance, thanks to the high efficiency DC fan motor, DC compressor and optimized refrigerant flow control logic.
- Precisely room temperature control by adopting 2000 pulse EXV. Indoor temperature fluctuation can be maintain within 0.5°C, offers outstanding comfort ability.

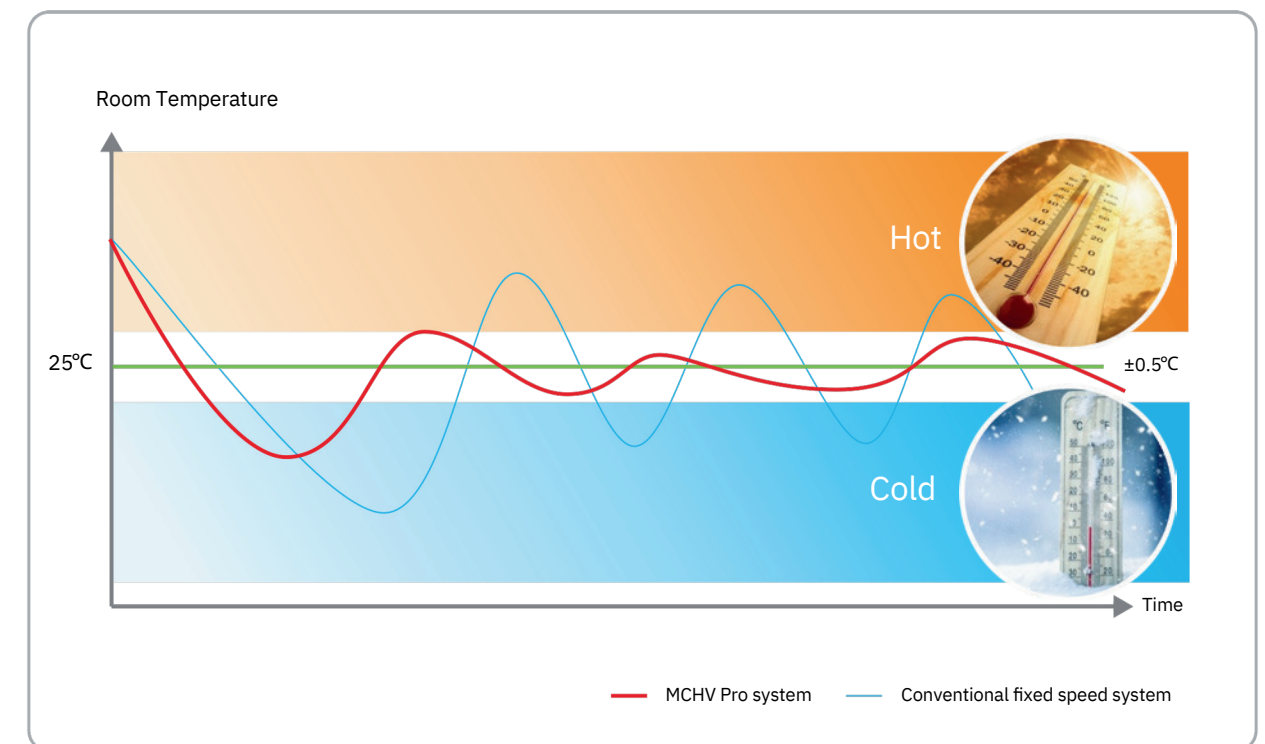

Wide Operation Range

MCHVpro has a wide ambient temperature operation range, cooling at -5-55 °C , and heating at -25-30 °C



Environmental Balanced Refrigerant

Refrigerant R410A(HFC), low carbon footprint, non-ozone depleting.

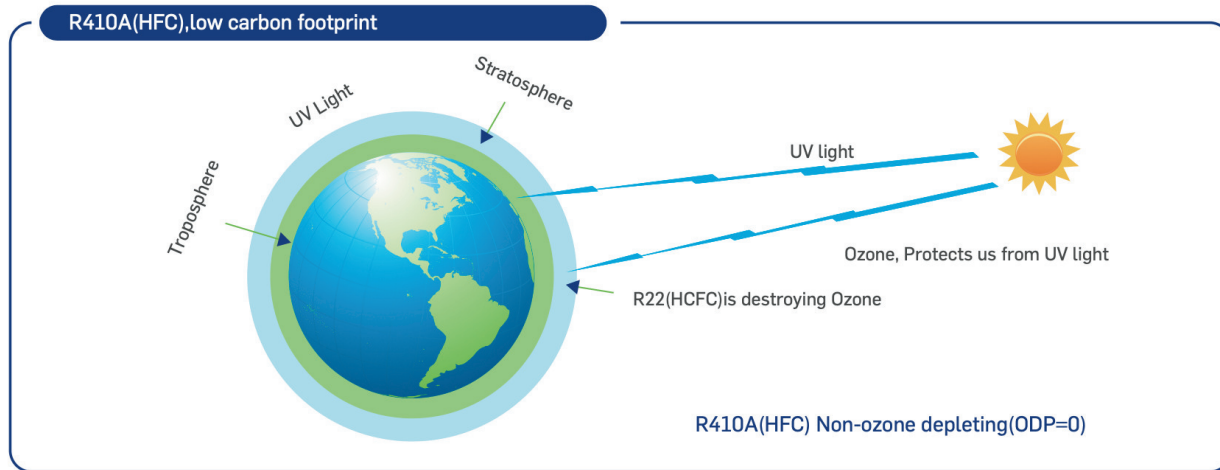

Snow-proof Function

In the cold weather, outdoor fan will start to run for a while at intervals to prevent the snow to accumulate on fan blade, because accumulated snow will freeze and block fan blade rotating, even worse it will damage the motor.



Night Mode

Compressor and fan motor rotating speed can be reduced to lower the noise at night. Maximum 10dB(A) decrease.

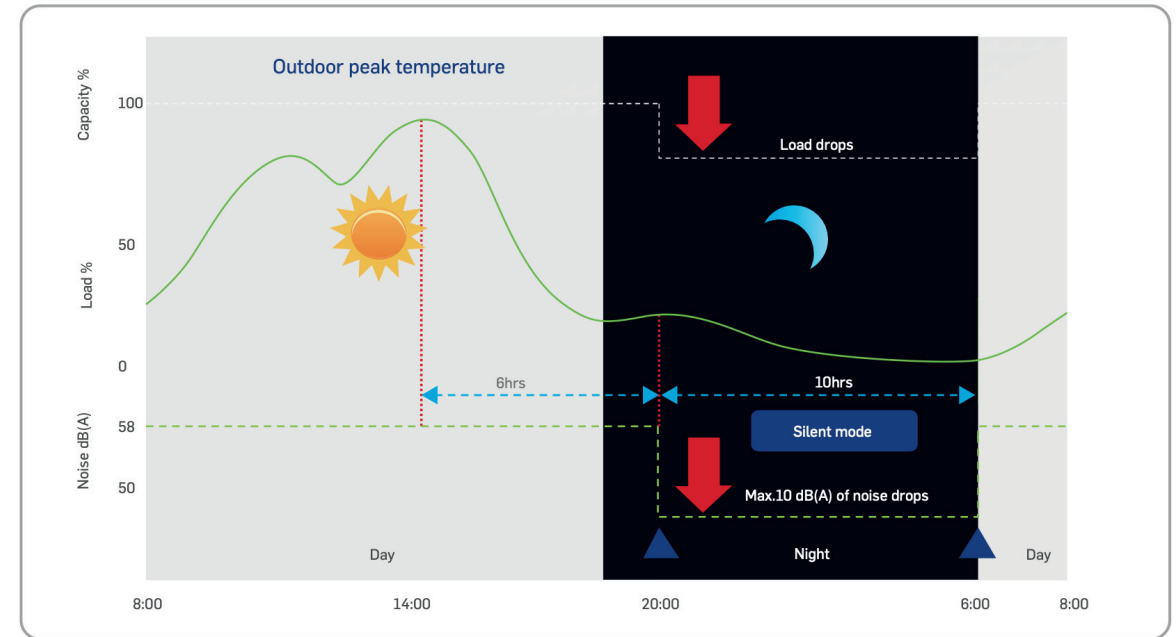

Low Noise Fan Blade

Fan blade with 7 noise reduction design, effectively reduce the noise while operation.

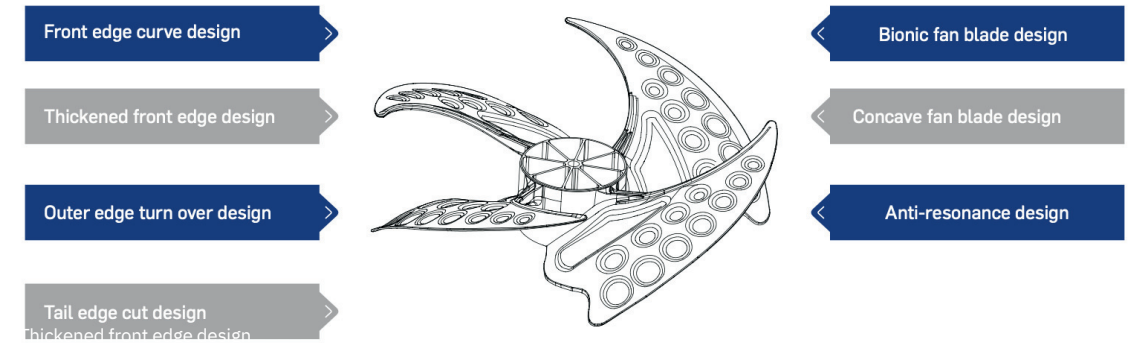

3-stage Back Up Function

Module back up function.
When some modules are failure, the others can keep running by simply settings.



Compressor back up function
When one compressor is failure, the other one can keep running by simply settings.



Fan motor back up function.
When one fan motor is failure, the other one can keep running by simply settings.



All Outdoor Units Cycle Operation

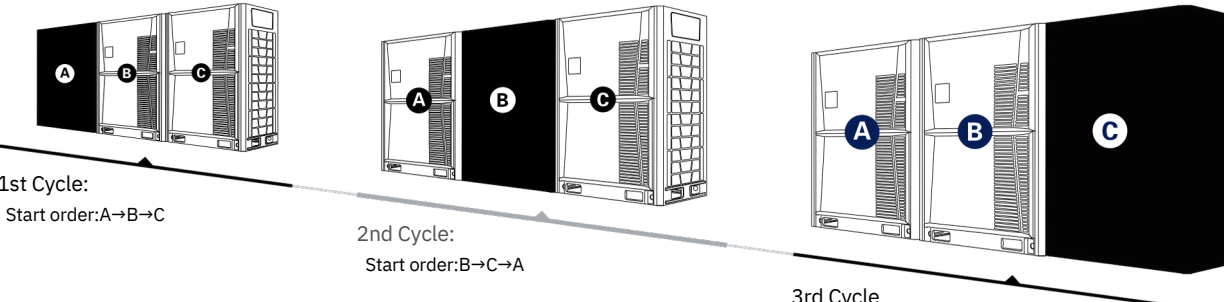

- In one combination system, any outdoor unit can run as master unit.
- Cycle operation equalizes the running time of the outdoor units, greatly extending the lifespan of outdoor units in one system.

IDU and ODU Positioning Function

Turn on the positioning function through the controller, and all the IDU and ODU of the same system will beep through the built-in buzzer, which is convenient for quick positioning during system commissioning, troubleshooting and after sales maintenance.



Remote ON/OFF Control Function

- Indoor units standard build in with ON/OFF control port.
- It can be used for hotel card control and also can be used for long distance remote ON/OFF control. And no need additional hotel VRF indoor unit control module.
- When contactor is open(card pulled out), indoor unit will be off can not be controlled, current running parameters will be saved in indoor PCB.
- When contactor is close(card insert), indoor unit will recover previous running state.

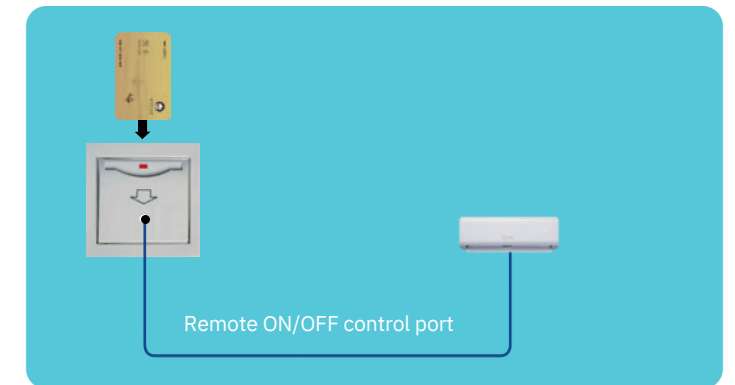

Intelligent Defrosting Program

5 special defrosting mechanisms

The dedicated temperature sensor monitors the temperature of the condenser coil of the outdoor unit in real time, intelligently selects the defrost mechanism and judges the timing of defrost, effectively prolongs the normal heating time, improves comfort, and achieves energy-saving effects.

- Normal temperature and low humidity defrosting mechanism
- Low temperature and low humidity defrosting mechanism
- Ultra-low temperature environment defrosting mechanism
- Normal temperature and high humidity defrosting mechanism
- Low temperature and high humidity defrosting mechanism

Defrost Curve

Program starts only when unit needs to. Whereas conventional unit's defrosting timing & duration is fixed, causing fluctuations in temperature and personal comfort.

- Conventional unit's defrosting timing & duration is fixed.
- Intelligent defrosting program starts according to heat exchanging efficiency & capacity change due to the frost. Less temperature fluctuations, people feel more comfortable

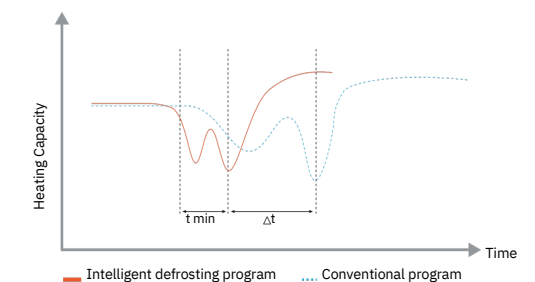

3

Benefits For Installers

Optimization for designer and installer

MCHV Pro DC inverter VRF system is designed with flexible modular combination concept, we keep optimizing the module size, reduce equipment on space occupied to meet the demand of designer and installer. Some unique technologies are used for our installers to reduce their working load, installation is becoming easier and easier.

Automatic Addressing

- Automatic addressing will reduce artificial faults by 35% and 5% manual works.
- 54% system failure were caused by communication faults.
- 65% communication faults were caused by address problems.
- Most of the address problems were: address setting forgotten, wrong settings, address repeat.

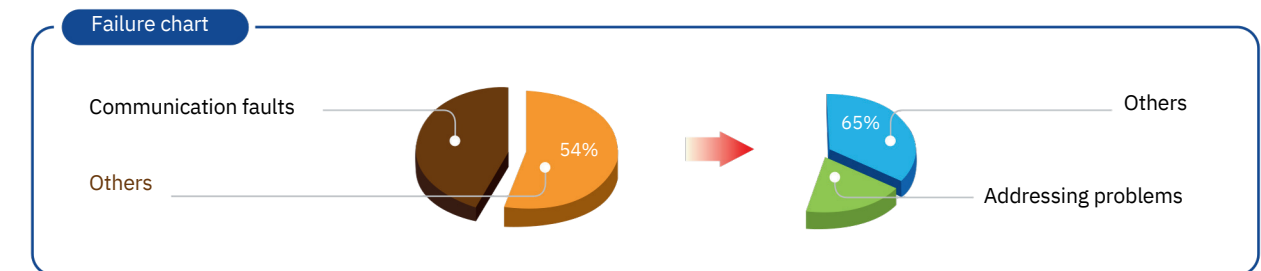

Adjustable Outdoor Fan Static Pressure

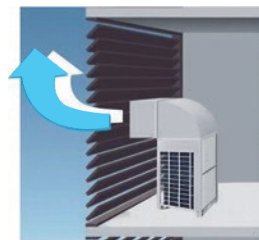

Thanks to DC fan motor, the external static pressure of outdoor fan is adjustable. Outdoor units can be installed in the service floor or facility room. Maximum ESP 80 Pa.

Touch Screen Wired Controller



- Air filter cleaning reminding function.
- Touch screen with black background and blue light.
- Ultra thin body and stylish design meet high-end environments.
- On/off, temperature setting, fan speed setting, mode setting, timer and check function.

New Wired Controller

- Bidirectional communication. Indoor unit's operating parameters (error code, temperature, address) can be inquired and displayed on the controller.
- Compact design.
- Timer function.

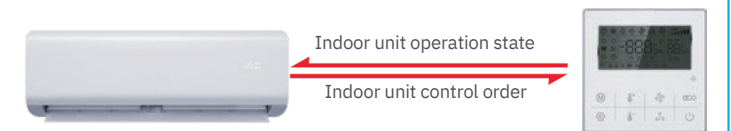

Digital Display On The PCB

- Digital display on the PCB, it can show system's operation status and error codes.



- Record error code list at main PCB chip, easy for service people to check.

Addressing Methods



- 2 addressing methods:
 - Automatically addressing: system will distribute address to indoor unit automatically.
 - Manually setting by wired controller or wireless remote controller.
- Addressing method can be selected easily by adjusting the switch on outdoor PCB.

Service Window

Thanks to the service window, checking outdoor unit's status and setting is now easy, no need to remove the electric control box cover.



Mode Restriction

- 6 kinds of mode restriction
 - Auto priority (Default Setting)
 - Cooling (or heating) priority mode.
 - Cooling only (or heating only) mode.
 - VIP unit priority + AUTO priority mode
- Mode restriction function can be selected on the outdoor PCB.

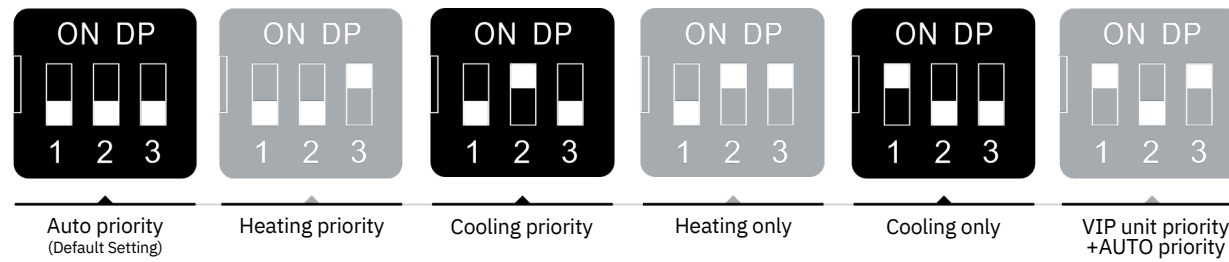

5-Stage Oil Control

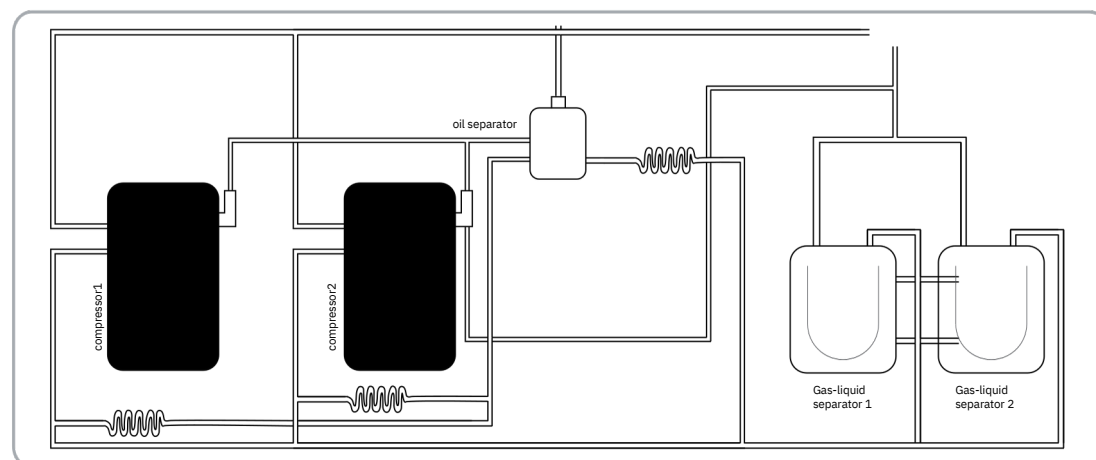

Humanized Internal Structure



- All key components are designed to close to outside, it is convenient for repair and replacement.
- Thanks to the new balance technology, gas balance pipe does no longer exist, brazing points and leaking risk are decreased.

3-Phase Power Protector (Optional)

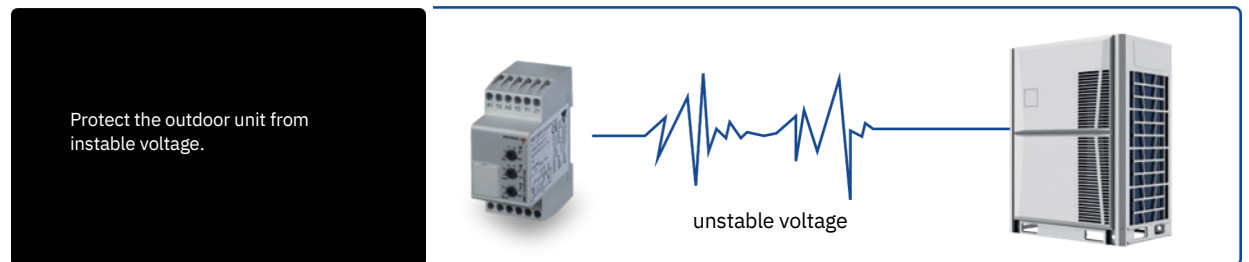

Easy Installation

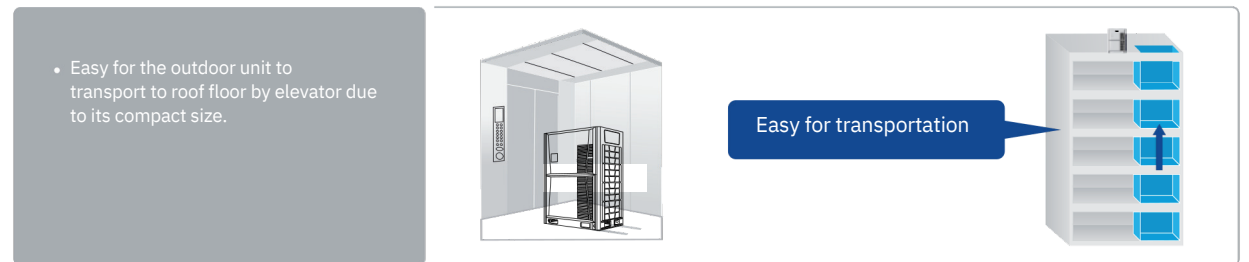

360° Pipe Connection



MCHV PRO HEAT PUMP (SCROLL COMPRESSOR)

SPECIFICATION

Model Name			MCHV-E252W/HZR1-DK01	MCHV-E280W/HZR1-DK01	MCHV-E335W/HZR1-DK01	MCHV-E400W/HZR1-DM01	MCHV-E450W/HZR1-DM01
Power Supply			380~415V/3N/50&60Hz				
PERFORMANCE DATA							
Cooling	Capacity	HP	8HP	10HP	12HP	14HP	16HP
		kW	25.2	28.0	33.5	40.0	45.0
		Btu/h	8600	95500	11400	13650	15350
	Rated current	RT	0.7.2	8.0	0.9.5	0.11.4	0.12.8
		A	9.04	11.30	14.51	18.10	21.60
		kW	5.31	6.22	8.35	9.76	11.63
		W/W	4.75	4.50	4.01	4.10	3.87
Heating	Capacity	kW	27.4	31.5	37.5	45.0	50.0
		Btu/h	9350	10750	12800	15350	17060
		RT	0.7.8	0.9.0	0.10.7	0.12.8	0.14.2
	Rated current	A	8.93	11.25	14.34	18.00	20.25
		kW	4.98	5.86	7.35	9.34	10.87
		W/W	5.50	5.38	5.10	4.82	4.60
COP							
Max. input consumption		kW	13.4	14.3	14.8	18.3	18.8
Max. Current		A	23.1	24.7	25.5	30.8	31.7
Capacity adjustment range			50%~130%				
COMPRESSOR DATA							
Compressor	Quantity		1				
	Type		Scroll Compressor				
	Brand		HITACHI				
PHYSICAL DATA							
Refrigerant	Type		R410a				
	Volume	Kg	9	11	14		
	Throttle type		EXV				
Dimension (WxHxD)	Net	mm	990x1740x840		1340x1740x840		
	Packing	mm	1060x1900x910		1410x1900x910		
Weight	Net	Kg	228	230	275		
	Gross	Kg	240	242	293		
Outdoor sound level		dB(A)	58	60	60	61	
Max. operating range			Mpa 4.5				
PIPING DATA							
Pipe size	Liquid pipe	mm	φ12.7		φ15.88		
	Gas pipe	mm	φ22.2		φ28.6		
Max. pipe length	Total pipe length	m	1000		1000		
	ODU to farthest IDU (Actual length)	m	200		200		
	ODU to farthest IDU (Equivalent length)	m	240		240		
	1st IDU distributor to farthest IDU	m	40/90		40/90		
Max. vertical length	Between ODU & IDU (ODU above IDU)	m	100		100		
	Between ODU & IDU (ODU below IDU)	m	110		110		
	Between IDUs	m	40		40		
	Between ODUs	m	0		0		
OPERATION TEMPERATURE RANGE							
Cooling	Outdoor side	℃	-5~55		-5~55		
	Indoor side	℃	16~32		16~32		
Heating	Outdoor side	℃	-25~30		-25~30		
	Indoor side	℃	16~32		16~32		

MCHV-E500W/HZR1-DM01	MCHV-E560W/HZR1-DM01	MCHV-E615W/HZR1-DM01	MCHV-E670W/HZR1-DS01	MCHV-E730W/HZR1-DS01	MCHV-E785W/HZR1-DS01	MCHV-E850W/HZR1-DS01	MCHV-E900W/HZR1-DS01
380~415V/3N/50&60Hz							
18HP	20HP	22HP	24HP	26HP	28HP	30HP	32HP
50.0	56.0	61.5	67.0	73.0	78.5	85.0	90.0
17060	19100	20980	22860	24910	26780	29000	30710
0.14.2	0.16.0	0.17.5	0.19.1	0.20.8	0.22.3	0.24.2	0.25.6
23.29	26.10	29.06	29.09	32.59	36.13	40.36	44.73
12.22	14.66	16.62	16.71	18.18	20.03	22.37	24.79
4.09	3.82	3.70	4.01	4.02	3.92	3.80	3.63
56.0	63.0	69.0	75.0	81.5	87.5	95.0	100.0
19100	21490	23540	25590	27810	29860	32410	34120
0.16.0	0.18.0	0.19.7	0.21.3	0.23.2	0.24.9	0.27.0	0.28.4
22.61	25.70	28.40	28.65	30.28	33.38	38.52	43.90
11.89	14.16	16.80	14.72	16.78	18.50	21.35	24.33
4.71	4.45	4.11	5.10	4.86	4.73	4.45	4.11
22.0	24.4	25.0	26.2	30.1	30.7	35.8	37.7
37.4	41.1	42.1	43.2	50.8	51.8	60.4	63.6
50%~130%							
1				2			
Scroll Compressor				Scroll Compressor			
HITACHI				HITACHI			
R410a							
15	16	20	23				
EXV							
1340x1740x840				1990x1740x840			
1410x1900x910				2060x1900x910			
285	29	297	388	433	480		
303	0	315	406	452	498		
62	30	63	62	63	64		
8				4.5			
φ15.88				φ22.2			
φ28.6				φ35.0			
1000				1000			
200				200			
240				240			
40/90				40/90			
100				100			
110				110			
40				40			
0				0			
-5~55				-5~55			
16~32				16~32			
-25~30				-25~30			
16~32				16~32			

Note

- Cooling operating temperature range is from -5°C to 55°C (It can be customized down to -10°C). Heating operating temperature range from -25°C to 30°C.
- The cooling conditions: indoor side 27°C(80.6°F) DB, 19°C(66°F) WB outdoor side 35°C(95°F) DB.
- The heating conditions: indoor side 20°C(68°F) DB, 15°C(44.6°F) WB outdoor side 7°C(42.8°F) DB.
- Sound level: measured at a point 1 m in front of the unit at a height of 1.5 m. During actual operation, these values are normally somewhat higher as a result of ambient conditions.
- The above data may be changed without notice for future improvement on quality and performance.

MCHV PRO HEAT PUMP (ROTARY COMPRESSOR)

SPECIFICATION

Model Name			MCHV-D252W/HZR1-DK01	MCHV-D280W/HZR1-DK01	MCHV-D335W/HZR1-DK01	MCHV-D400W/HZR1-DM01	MCHV-D450W/HZR1-DM01	
Power Supply			380~415V/3N/50Hz		380~415V/3N/50Hz		380~415V/3N/50Hz	
PERFORMANCE DATA								
Cooling	Capacity	HP	8HP		10HP		12HP	
		kW	25.2		28.0		33.5	
		Btu/h	86000		95500		114000	
	Rated current	RT	7.2		8.0		9.5	
		A	10.20		11.80		15.50	
		kW	5.50		7.00		9.20	
		W/W	4.64		4.07		3.64	
Heating	Capacity	kW	27.0		31.5		37.5	
		Btu/h	92100		107500		128000	
		RT	7.7		9.0		10.7	
	Rated current	A	10.00		11.60		15.40	
		kW	5.75		6.90		9.10	
		W/W	4.70		4.57		4.12	
		COP	4.70		4.57		4.12	
Max. input consumption		kW	13.96		13.96		13.96	
Max. Current		A	24.0		24.0		24.0	
Capacity adjustment range			50%~130%					
COMPRESSOR DATA								
Compressor	Quantity		1					
	Type		Rotary Compressor					
	Brand		Mitsubishi					
PHYSICAL DATA								
Refrigerant	Type		R410a					
	Volume	Kg	9		11		14	
	Throttle type		EXV					
Dimension (WxHxD)	Net	mm	990x1740x840			1340x1740x840		
	Packing	mm	1060x1900x910			1410x1900x910		
Weight	Net	Kg	205		210		250	
	Gross	Kg	217		222		268	
Outdoor sound level		dB(A)	58		58		60	
Max. operating range		Mpa	4.5					
PIPING DATA								
Pipe size	Liquid pipe	mm	φ12.7		φ15.88		φ15.88	
	Gas pipe	mm	φ22.2		φ28.6		φ28.6	
Max. pipe length	Total pipe length	m	1000		1000		1000	
	ODU to farthest IDU (Actual length)	m	200		200		200	
	ODU to farthest IDU (Equivalent length)	m	240		240		240	
	1st IDU distributor to farthest IDU	m	40/90		40/90		40/90	
Max. vertical length	Between ODU & IDU (ODU above IDU)	m	100		100		100	
	Between ODU & IDU (ODU below IDU)	m	110		110		110	
	Between IDUs	m	40		40		40	
	Between ODUs	m	0		0		0	
OPERATION TEMPERATURE RANGE								
Cooling	Outdoor side	℃	-5~55		-5~55		-5~55	
	Indoor side	℃	16~32		16~32		16~32	
Heating	Outdoor side	℃	-15~30		-15~30		-15~30	
	Indoor side	℃	16~32		16~32		16~32	

MCHV-D500W/HZR1-DM01	MCHV-D560W/HZR1-DM01	MCHV-D615W/HZR1-DM01	MCHV-D670W/HZR1-DS01	MCHV-D730W/HZR1-DS01	MCHV-D800W/HZR1-DS01	MCHV-D850W/HZR1-DS01	
380~415V/3N/50Hz		380~415V/3N/50Hz		380~415V/3N/50Hz		380~415V/3N/50Hz	
18HP	20HP	22HP	24HP	26HP	28HP	30HP	
50.0	56.0	61.5	67.0	73.0	80.0	85.0	
170600	191000	209800	228600	249000	272900	290000	
14.2	16.0	17.5	19.1	20.9	22.7	24.2	
24.80	29.60	31.50	36.70	34.60	36.90	46.70	
14.70	17.60	18.70	21.74	20.54	25.50	27.71	
3.40	3.18	3.29	3.08	3.55	3.14	3.07	
56.0	63.0	69.0	75.0	81.5	88.0	95.0	
191000	214900	235400	255800	278100	300300	324100	
16.0	18.0	19.7	21.4	23.3	25.1	27.0	
24.10	29.10	30.80	30.30	35.40	37.70	46.50	
14.30	17.20	18.20	17.94	20.96	24.10	27.60	
3.92	3.66	3.79	4.18	3.89	3.65	3.44	
22.0	24.4	25.0	27.6	35.3	35.3	37.6	
37.4	41.1	43.1	45.4	59.6	59.6	63.4	
50%~130%							
2							
Rotary Compressor							
Mitsubishi							
R410a							
15	16	20	23				
EXV							
1340x1740x840			1990x1740x840				
1410x1900x910			2060x1900x910				
300	309	352	412	452			
310	319	370	430	470			
62	63	65	66				
4.5							
φ15.88							
φ28.6							
1000							
200							
240							
40/90							
100							
110							
40							
0							
-5~55							
16~32							
-15~30							
16~32							

Note

- Cooling operating temperature range is from -5°C to 55°C (It can be customized down to -10°C). Heating operating temperature range is from -15°C to 30°C.
- The cooling conditions: indoor side 27°C(80.6°F) DB, 19°C(60°F)WB outdoor side 35°C(95°F) DB.
- The heating conditions: indoor side 20°C(68°F) DB, 15°C(44.6°F)WB outdoor side 7°C(42.8°F) DB.
- Sound level: measured at a point 1 m in front of the unit at a height of 1.5 m. During actual operation, these values are normally somewhat higher as a result of ambient conditions.
- The above data may be changed without notice for future improvement on quality and performance.

MCHV PRO COOLING ONLY

SPECIFICATION

Model Name			MCHV-D252W/CZR1-DK02	MCHV-D280W/CZR1-DK02	MCHV-D335W/CZR1-DK02	MCHV-D400W/CZR1-DM02	MCHV-D450W/CZR1-DM02	MCHV-D500W/CZR1-DM02
Power Supply			380~415V/3N/50Hz					
PERFORMANCE DATA								
Cooling	Capacity	HP	8HP	10HP	12HP	14HP	16HP	18HP
		kW	25.2	28	33.5	40	45	50
		Btu/h	86000	95500	114000	136500	153500	170600
	Power input	RT	7.2	8	9.5	11.4	12.8	14.2
		kW	5.5	7	9.2	10.8	12.80	14.70
EER	W/W	4.64	4.07	3.64	3.7	3.52	3.40	
Max. input consumption		kW	13.96	13.96	13.96	17.83	17.83	18.8
Max. current		A	24	24	24	29	29	31.7
Capacity adjustment range			50%~130%					
COMPRESSOR DATA								
DC Inverter compressor	Quantity		1					
	Type		DC/Twin-rotary					
	Brand		Mitsubishi					
	Frequency range		Hz 30~360					
PHYSICAL DATA								
Refrigerant	Type		R410a					
	Quantity	kg	9	11	14			
Dimension (DxHxW)	Net	mm	840x1740x990			840x1740x1340		
	Packing	mm	910x1900x1060			910x1900x1410		
Weight	Net	Kg	205	210	250		270	
	Gross	Kg	217	222	268		280	
Outdoor sound level		dB(A)	58	58	60		61	
Maximum operating pressure		MPa	4.5					
PIPING & WIRING DATA								
Pipe size	Liquid pipe	mm	φ12.7			φ15.88		
	Gas pipe	mm	φ22.2			φ28.6		
Max. pipe length	Total pipe length		m 1000					
	From OU to farthest IU (Actual length)		m 200					
	From OU to farthest IU (Equivalent length)		m 240					
	From first manifold to the furthest IDU		m 40/90					
Max. Vertical length	Between OU & IU (OU above IU)		m 100					
	Between OU & IU (OU below IU)		m 110					
	Between IUs		m 40					
	Between Ous		m 0					
Operation Temperature Range								
Cooling	Outdoor side		°C -5~55					
	Indoor side		°C 16~32					

MCHV-D560W/CZR1-DM02	MCHV-D615W/CZR1-DM02	MCHV-D670W/CZR1-DM02	MCHV-D730W/CZR1-DS02	MCHV-D800W/CZR1-DS02	MCHV-D850W/CZR1-DS02	MCHV-D900W/CZR1-DS02
380~415V/3N/50Hz						
PERFORMANCE DATA						
20HP	22HP	24HP	26HP	28HP	30HP	32HP
56	61.5	67	73	80	85	90
191000	209800	228600	249000	272900	290000	307000
16	17.5	19.1	20.9	22.7	24.2	25.6
17.60	18.70	21.74	20.54	25.50	28.08	32.23
3.18	3.29	3.08	3.55	3.14	3.03	2.79
22.0	24.4	25.0	27.6	35.3	35.3	37.6
37.4	41.1	43.1	45.4	59.6	59.6	63.4
Capacity adjustment range						
50%~130%						
COMPRESSOR DATA						
Quantity 2						
Type DC/Twin-rotary						
Brand Mitsubishi						
Frequency range Hz 30~360						
PHYSICAL DATA						
Type R410a						
15	16		20		23	
840x1740x1340			840x1740x1990			
910x1900x1410			910x1900x2060			
300		309	352	412		452
310		319	370	430		470
62	63	63	63	66		66
Maximum operating pressure						
4.5						
PIPING & WIRING DATA						
Liquid pipe φ15.88						
Gas pipe φ22.2 φ28.6 φ35						
Total pipe length 1000						
From OU to farthest IU (Actual length) 200						
From OU to farthest IU (Equivalent length) 240						
From first manifold to the furthest IDU 40/90						
Between OU & IU (OU above IU) 100						
Between OU & IU (OU below IU) 110						
Between IUs 40						
Between Ous 0						
Operation Temperature Range						
Outdoor side -5~55						
Indoor side 16~32						

MCHV PRO HEAT PUMP (60HZ)

SPECIFICATION

Model Name			MCHV-D252W/HXR1	MCHV-D280W/HXR1	MCHV-D335W/HXR1	MCHV-D400W/HXR1
Power Supply			208~230V/3N/60Hz	208~230V/3N/60Hz	208~230V/3N/60Hz	208~230V/3N/60Hz
PERFORMANCE DATA						
Cooling	Capacity	HP	8HP	10HP	12HP	14HP
		kW	25.2	28.0	33.5	40.0
		Btu/h	85000	93800	114000	136500
		RT	7.1	7.9	9.5	11.4
	Power input	kW	5.28	6.25	7.86	9.33
EER	W/W	4.77	4.48	4.26	4.29	
Heating	Capacity	kW	27.4	31.5	37.5	45
		Btu/h	93500	107500	128000	153500
		RT	7.8	9	10.7	12.8
	Power input	kW	5.46	6.58	8.61	9.32
EER	W/W	5.02	4.79	4.36	4.83	
Capacity adjustment range			50%~130%			
COMPRESSOR DATA						
Compressor	Quantity		1			
	Type		DC /Scroll			
	Brand		Mitsubishi			
PHYSICAL DATA						
Refrigerant type/volume		kg	R410A/12		R410A/16	
Dimension (DxHxW)	Net	mm	840x1740x990		840x1740x1340	
	Packing	mm	910x1900x1060		910x1900x1410	
Weight	Net	kg	220		275	
	Gross	kg	230		290	
Outdoor sound level		dB(A)	67		71	
Maximum operating pressure		MPa	4.5			
PIPING DATA						
Pipe size	Liquid pipe	mm	Ø12.7		Ø15.9	
	Gas pipe	mm	Ø22.2		Ø28.6	
Max. pipe length	Total pipe length		1000			
	From OU to farthest IU(Actual length)		190			
	From OU to farthest IU (Equivalent length)		220			
	From 1st indoor distributor to farthest IU		40			
Max. Vertical length	Between OU & IU (OU above IU)		90			
	Between OU & IU (OU below IU)		110			
	Between IUs		30			
	Between Ous		0			
OPERATION TEMPERATURE RANGE						
Cooling	Outdoor side		-5~55			
	Indoor side		17~32			
Heating	Outdoor side		-15~30			
	Indoor side		15~30			

MCHV-D450W/HXR1	MCHV-D500W/HXR1	MCHV-D560W/HXR1	MCHV-D615W/HXR1
208~230V/3N/60Hz	208~230V/3N/60Hz	208~230V/3N/60Hz	208~230V/3N/60Hz
16HP	18HP	20HP	22HP
45.0	50.0	56.0	61.5
153500	169000	191000	209800
12.8	14.1	16	17.5
11.12	12.68	15.32	17.62
4.05	3.94	3.66	3.49
50	56	63	69
170600	191000	214900	235400
14.2	16	18	19.7
10.59	12.54	14.88	17.52
4.72	4.47	4.23	3.94
50%~130%			
1	2		
DC /Scroll			
Mitsubishi			
R410A/16	R410A/20		
840x1740x1340			
910x1900x1410			
275	325		
290	340		
71	72		
4.5			
Ø15.9			
Ø28.6			
1000			
190			
220			
40			
90			
110			
30			
0			
-5~55			
17~32			
-15~30			
15~30			

MCHV PRO COOLING ONLY (60HZ)

SPECIFICATION

Model Name			MCHV-D252W/CXR1-DK01	MCHV-D280W/CXR1-DK01	MCHV-D335W/CXR1-DK01	MCHV-D400W/CXR1-DM01
Power Supply			208~230V/3N/60Hz			
PERFORMANCE DATA						
Cooling	Capacity	HP	8HP	10HP	12HP	14HP
		kW	25.2	28.0	33.5	40.0
		Btu/h	86000	95500	114000	136500
		RT	7.2	8.0	9.5	11.4
	Power input	kW	5.82	6.81	9.05	10.47
	EER	W/W	4.33	4.11	3.70	3.82
Rated, input consumption		kW	13.50	14.10	14.20	16.90
Rated, current		A	40.0	42.0	45.0	50.0
Capacity adjustment range			50%~130%			
COMPRESSOR DATA						
DC Inverter compressor	Quantity		1			
	Type		DC /Twin-rotary			
	Brand		Mitsubishi			
	Frequency range		rps 10-120			
Physical Data	Type		R410a			
	Volume	Kg	8		12	
Dimension (DxHxW)	Net	mm	840x1740x990		840x1740x1340	
	Packing	mm	910x1900x1060		910x1900x1410	
Weight	Net	Kg	208		260	
	Gross	Kg	218		278	
Outdoor sound level		dB(A)	58		60	
Maximum operating pressure		MPa	4.5			
PIPING & WIRING DATA						
Pipe size	Liquid pipe	mm	φ12.7		φ15.9	
	Gas pipe	mm	φ25.4		φ31.8	
Max. pipe length	Total pipe length		m 1000			
	From OU to farthest IU (Actual length)		m 190			
	From OU to farthest IU (Equivalent length)		m 220			
	From 1st indoor distributor to farthest IU		m 90			
Max. Vertical length	Between OU & IU (OU above IU)		m 90			
	Between OU & IU (OU below IU)		m 110			
	Between IUs		m 30			
	Between Ous		m 0			
OPERATION TEMPERATURE RANGE						
Cooling	Outdoor side		°C -5~50			
	Indoor side		°C 16~32			

MCHV-D450W/CXR1-DM01	MCHV-D500W/CXR1-DM01	MCHV-D560W/CXR1-DM01	MCHV-D615W/CXR1-DM01	MCHV-D670W/CXR1-DM01
208~230V/3N/60Hz				
16HP	18HP	20HP	22HP	24HP
45.0	50.0	56.0	61.5	67.0
153500	170600	191000	209800	228600
12.8	14.2	16.0	17.5	19.0
12.13	14.62	17.13	19.84	22.11
3.71	3.42	3.27	3.10	3.03
17.30	24.00	26.50	27.00	27.00
53.0	70.0	78.0	80.0	80.0
50%~130%				
1	2			
DC /Twin-rotary				
Mitsubishi				
10~120				
R410a				
12	13	14	14	15
840x1740x1340				
910x1900x1410				
260	288	296	296	306
278	306	314	314	324
61	62	63	63	63
4.5				
φ15.9				
φ31.8				
1000				
190				
220				
90				
90				
110				
30				
0				
-5~50				
16~32				

SIDE DISCHARGE MODULAR VRF SYSTEM

FEATURES & SPECIFICATION



10-22HP

Free Combination

- Single module from 10-22HP
- Free combination with 4 modules, capacity up to 88HP
- Max. 100 IDUs can be connect in one system



Small Footprint

Compared with top discharge VRF, the side discharge VRF requires smaller space, and allows to install at the balcony

Side Discharge Type



The footprint of 88HP: 2.75 m²

Top Discharge Type



The footprint of 88HP: 4.02 m²

Compressor Control

Toshiba high efficiency compressor, The speed control accuracy up to 0.1Hz, built in oil temperature sensor improves the reliability



Motor Control

- 3phase DC motor, balance the power consumption, reduce the impact to grid
- Strong air flow, long distance up to 10m without duct
- Max. ESP up to 80Pa

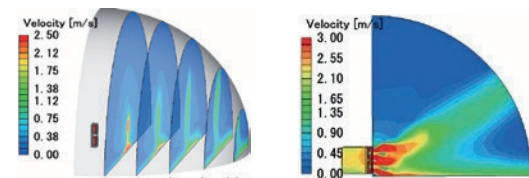

Consistent Heating

Consistent heating function, always provide the heat air, comfort experience.



Wide Outdoor Operation Range

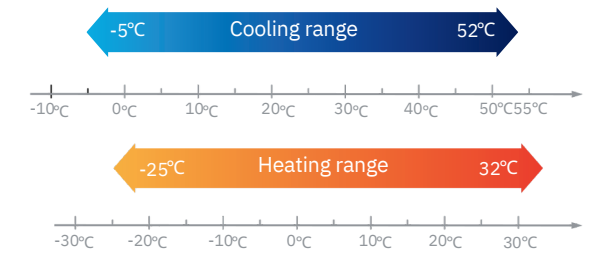

*Based on MCHV internal test report

USB Port Available

USB port to support software update and parameter record.

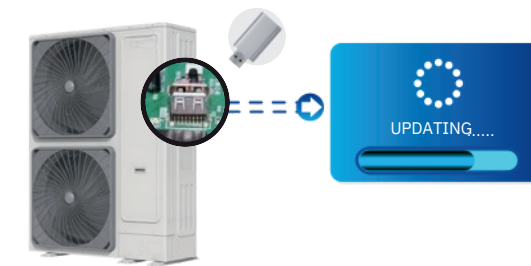

Long Refrigerant Piping

The total pipe length	560m
Height difference between indoor and outdoor unit:	60m
indoor units	20m

*Please refer to the installation manual for detailed length description.

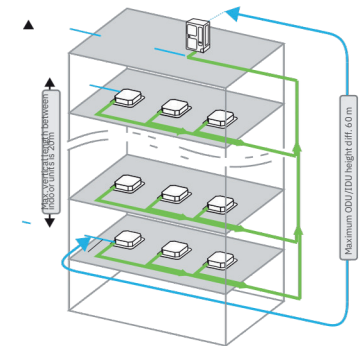

Diagnosis Software

The advanced intelligent diagnostic debugging software is used to debug and diagnose the air conditioning roundly with great rapidity, easy to use.



Benefit IDU Service

When one indoor unit which has failed needs to be repaired, the indoor unit can be turn off to repair the failure and other indoor units keep operate normally.

Black Box

The outdoor unit is equipped with the "black box" data automatic storage device, which records all kinds of running information and data of the system when a fault occurs.

Capacity		10	12	14	16	18	20	22	
Power Supply		380V~450V/3N/50&60Hz							
Performance Data									
Cooling	Capacity	kW	28.5	33.5	40	45	50.5	56	61.5
	Power input	kW	5.79	7.29	11.82	11.4	16.44	16.63	20.58
	EER*	kW/kW	4.92	4.6	3.38	3.95	3.07	3.37	2.99
Heating	Capacity	kW	31.5	37.5	45	50	56	63	69
	Power input	kW	6.37	7.48	9.55	11.25	12.68	13.65	15.37
	COP*	kW/kW	4.95	5.01	4.71	4.44	4.42	4.62	4.49
Sound pressure level		dB(A)	57	58	59	60	61	61	63
Max. external static pressure		Pa	35	35	35	35	35	35	35
Operation temp. range	Cooling	CDB	-5°C~52°C	-5°C~52°C	-5°C~52°C	-5°C~52°C	-5°C~52°C	-5°C~52°C	-5°C~52°C
	Heating	CWB	-25°C~32°C	-25°C~32°C	-25°C~32°C	-25°C~32°C	-25°C~32°C	-25°C~32°C	-25°C~32°C
Piping length	Max. total pipe length	m	560	560	560	560	560	560	560
	Max. diff. between IDU	m	20	20	20	20	20	20	20
	Max. diff. between ODU/IDU	m	60	60	60	60	60	60	60

*Note: The power supply also support up to 450 voltage and 60Hz. Draft data basing on GB standard

HEAT RECOVERY MINI VRF SYSTEM

FEATURES



8/10/12.5/14 kW



Hydro kit

Concept of HR Mini VRF

The heat recovery Mini VRF system is an integrated solution for space cooling and heating through the combination of ATA & ATW applications. It can be connected to a regular VRF indoor unit for cooling, or to a hydronic kit to produce hot water for floor heating and radiators, or to provide DHW for showers.

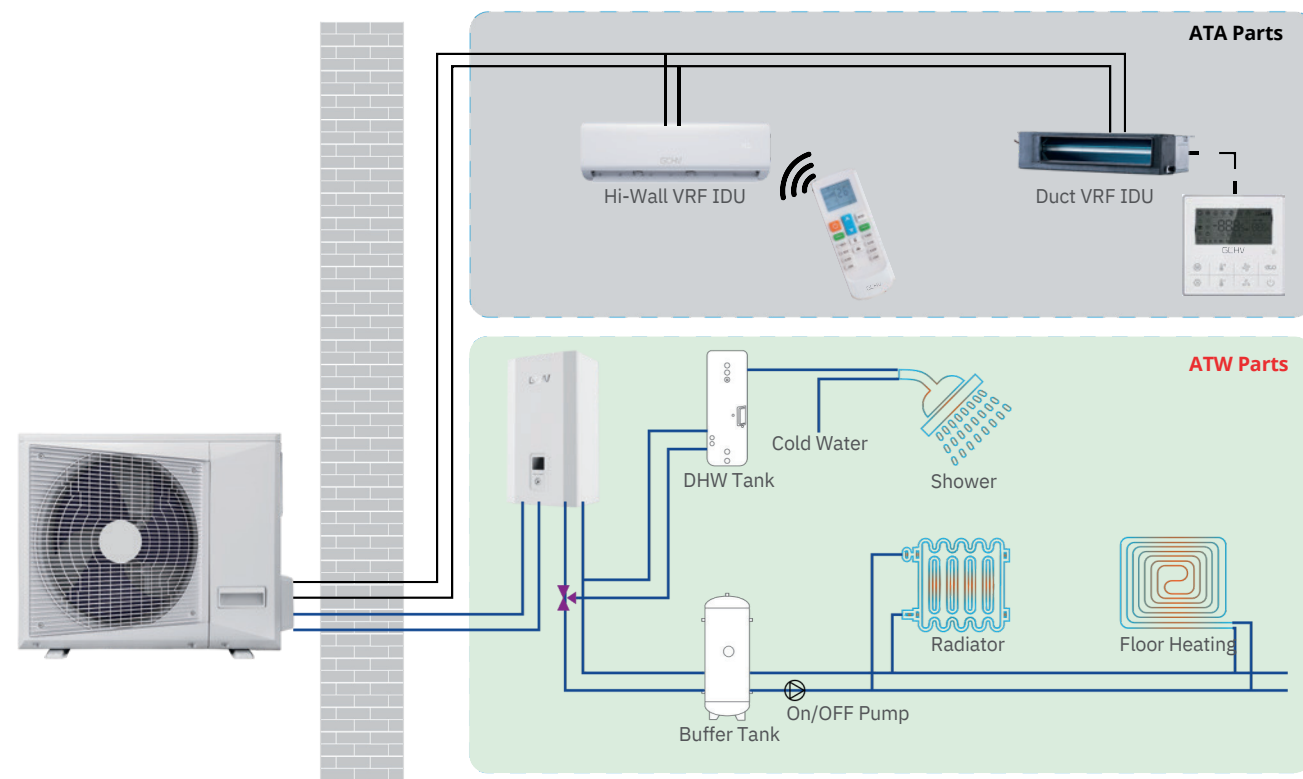

Heat Recovery Mini VRF System

The heat recovery Mini VRF system is an integrated solution for space cooling and heating through the combination of ATA & ATW applications. It can be connected to a regular VRF indoor unit for cooling, or to a hydronic kit to produce hot water for floor heating and radiators, or to provide DHW for showers.

- Cooling in summer via ATA and free DHW water supply
- Space heating in winter via ATA/ATW and DHW water supply
- In spring and autumn, ATA cooling and ATW heating can be used at the same time to adapt to different room applications

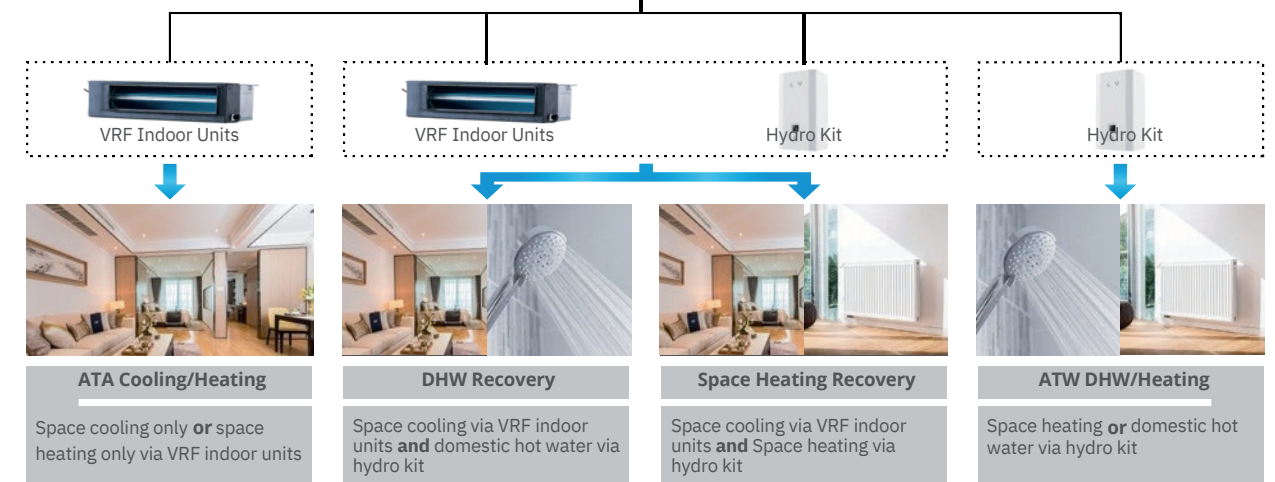

Outdoor Unit Features

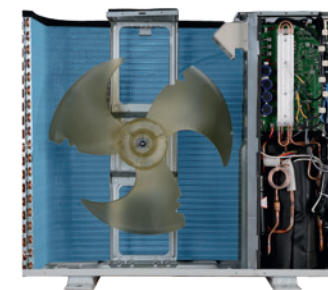

- **Mitsubishi Twin-rotary Compressor**
Mitsubishi Twin-rotary compressor with stepless control to help the system operate more precisely and smoothly in a constant & free frequency.
- **Two System In One Outdoor Unit**
Two 4-way valve & EXV with 4 pipes, one set for air conditioning system and the other for water system, adopts heat recovery technology for high efficiency.
- **High-efficiency DC Motor**
High-efficiency DC motor and optimized the fan speed to suit the different condition to achieve better performance.
- **Large Air Volume**
Bigger fan blade and low air resistance grille to obtain larger air volume to improve the system performance.

Hydro Kit Features



- **Touch Wired Controller**
Touch wired controller, easy and friendly to operate.
- **Inverter Water Pump**
Multi-speed to adjust the water flow rate according to capacity demand.
- **Electrical Heater**
3kw electrical heater, provide additional heat in case of low ambient temp. to promise the heating capacity.
- **Water Flow Switch**
Water flow switch to protect the system to avoid the BPHE freezing.
- **Easy Commissioning**
Water pressure gauge & safety valve to obtain the easy commissioning and service.

FEATURES

Long Refrigerant Piping

The total pipe length	100m
The longest pipe length	Actual length 60m Equivalent length 70m
Equivalent length from first indoor distributor to last indoor unit	20m
Height difference between indoor and outdoor unit:	Outdoor unit above ≤20m Outdoor unit below ≤30m
Height difference between indoor units	8m

*Please refer to the installation manual for detailed length description.

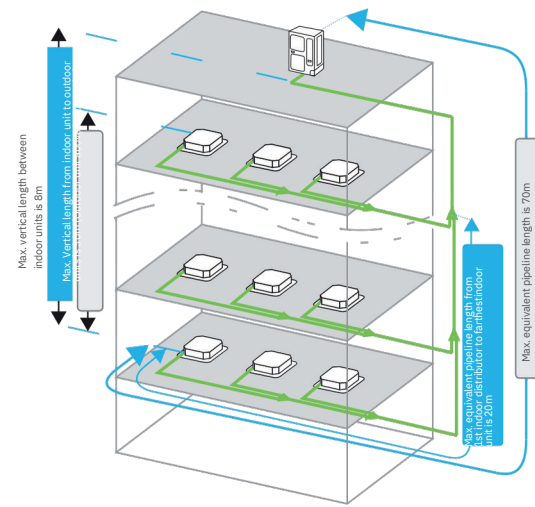

High Efficiency

Adopt the full DC inverter technology to achieve high efficiency.

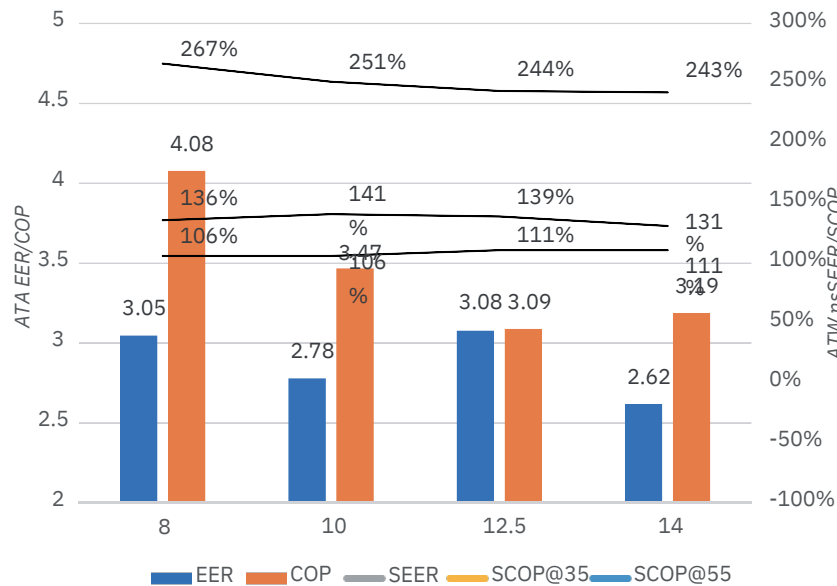

High Efficiency Compressor
Twin-rotary DC inverter compressor, constant & stepless output.



Brushless DC Motor
Brushless DC Motor to obtain the best air flow to make sure the heat exchange performance.



Brushless DC Pump
Brushless DC pumps for hydronic kits allow for precise water temp. control.

High Leaving Water Temperature

The heat recovery Mini VRF has a wide operation ambient temperature range from -20°C to 43°C for heating/DHW, and 7-43°C for heat recovery mode, it provides the hot water all year round and the leaving water temp. up to 55°C, it is very suitable for residential and light commercial projects.

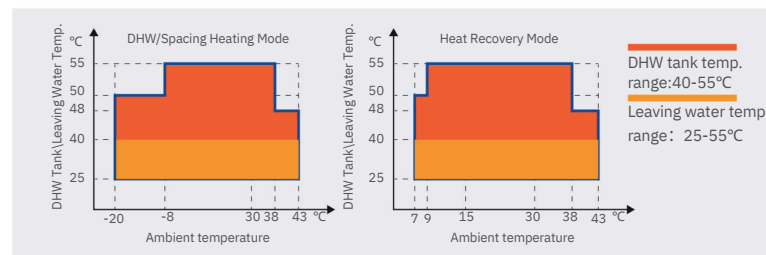

FEATURES

Wide Outdoor Operation Range

• ATACooling: -15~55 °C • ATAHeating: -20~30 °C • DHW/Space heating: -20~43 °C • Heat Recovery: 7~43 °C

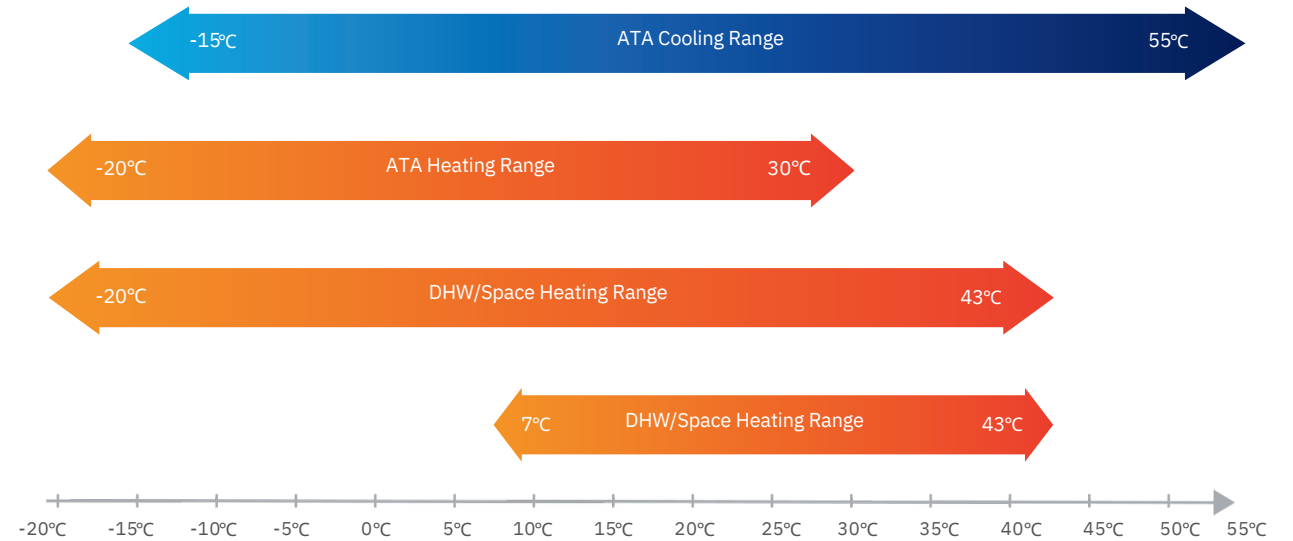

Outstanding Comfort Ability

- Precisely room temperature control by adopting 2000 pulse EXV and high-precision sensor. Indoor temperature fluctuation can be maintaining within 0.5°C, offers outstanding comfort ability.
- Space cooling through the air condition to flow the cold air from ceiling of room & space heating through the floor heating/radiator to warm the house from floor of room, which is more comfortable way to human feeling in cold/heat condition.

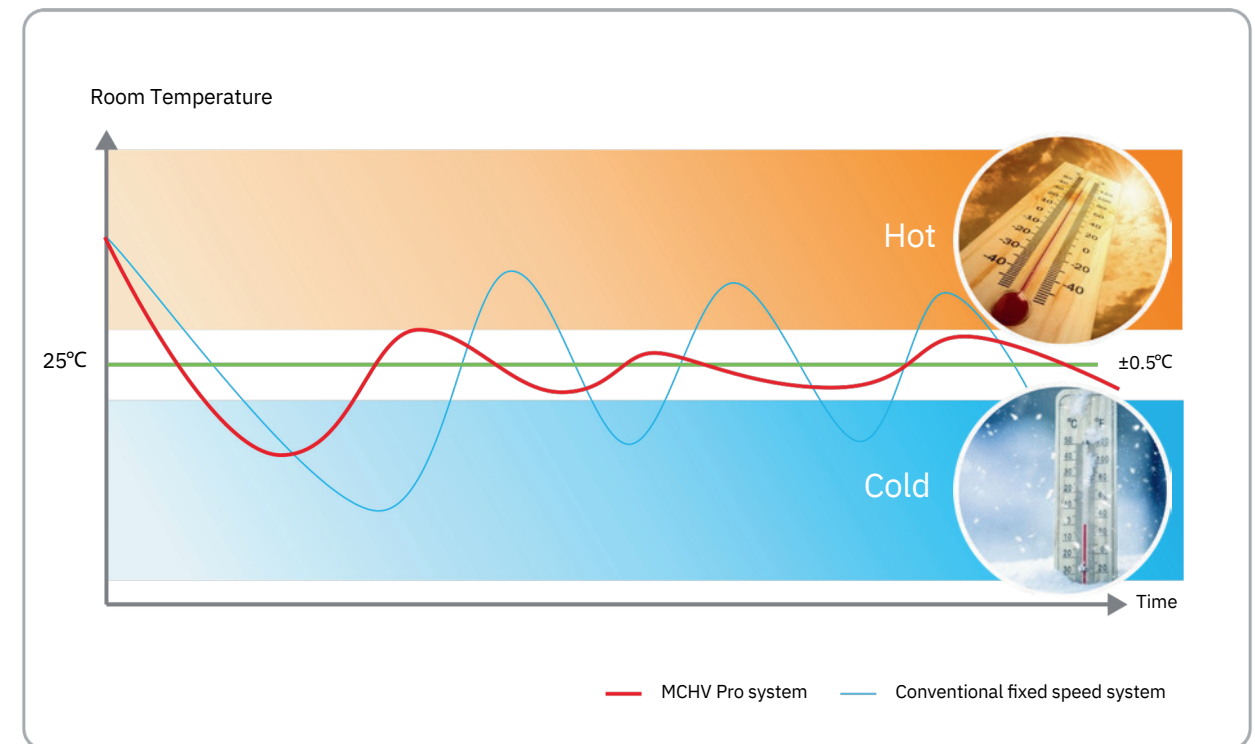

FEATURES

Auto Addressing

The address of indoor units is allocated automatically by the system, no need to edit by dialing, which saves the hassle of manual setting one by one.



2 addressing methods:

- Automatically addressing: system will distribute address to indoor unit automatically.
- Manually setting by wired controller or wireless remote controller.

Addressing method can be selected easily by adjusting the switch on outdoor PCB.

Refrigerant Cooling Tech. For PCB

- Good performance with enhanced refrigerant cooling solution
- Intelligent refrigerant control technology to protect PCB
- Quick action speed to make the main PCB working at suitable temperature range
- High reliability

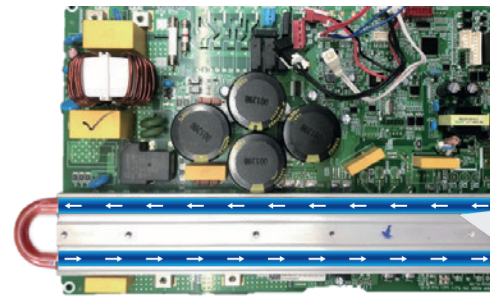

The cold refrigerant flows through the PCB and takes away the heat of the PCB through the aluminum heat exchange plate to ensure the long-term stable operation.

Service Window

- Service window on the right side to connect the cable and digital display to check the running data.
- One button to start the system to do the running test.



SPECIFICATION

Outdoor Unit		MCHV-VH080R1-(BR)D-F01	MCHV-VH100R1-(BR)D-F01	MCHV-VH125R1-(BR)D-F01	MCHV-VH140R1-(BR)D-F04	
Power Supply		220~240V/1N/50Hz	220~240V/1N/50Hz	220~240V/1N/50Hz	220~240V/1N/50Hz	
Performance Data						
Max. power input	W	6500	6500	6500	6500	
Max. current	A	30	30	30	30	
ATA capacity	Cooling capacity	kW	8.0	10.0	12.5	14.0
	Power Input	kW	2.60	3.64	4.04	4.60
	EER	W/W	3.07	2.78	3.09	3.02
	Heating Capacity	kW	8.0	10.0	12.5	14.0
	Power Input	kW	2.05	3.00	4.04	4.61
	COP	W/W	4.08	3.47	3.09	3.04
ATW capacity	SEER		6.74	6.36	6.17	6.14
	SCOP		4.05	4.05	4.62	4.62
	A7W45	kW	10.51	12.58	14.32	16.59
	COP	W/W	4.02	3.61	3.21	2.98
	Capacity@A2W35	kW	12.26	14.78	12.2	14.4
	COP@A2W35	W/W	3.21	3.02	3.52	3.42
	Capacity@A7W35	kW	14.61	15.71	14.20	16.40
	COP@A7W35	W/W	3.65	3.55	3.62	3.58
	Capacity@A-7W35	kW	8.42	9.92	10.50	11.80
	COP@A-7W35	W/W	2.42	2.39	3.32	3.31
SCOP @W35/W55 (average climate)			3.48/2.73	3.61/2.73	3.35/2.86	3.35/2.86
Energy efficiency η ₁ @W35/W55 (average climate)			136%/106%	141%/106%	139%/111%	131%/111%
Energy class @W35/W55			A+/A+	A+/A+	A+/A+	A+/A+
Capacity with heat recovery	W55 ATA+ATW	kW	27.0	27.2	28.1	28.6
	Power input	kW	4.20	4.11	4.37	4.58
	Energy efficiency	W/W	6.47	6.61	6.43	6.24
Outdoor temperature range	Cooling	°C	-15~55	-15~55	-15~55	-15~55
	Heating	°C	-20~30	-20~30	-20~30	-20~30
	DHW	°C	-20~40	-20~40	-20~40	-20~40
Water outlet temperature	Cooling + Hot Water	°C	7~43	7~43	7~43	7~43
	Heating	°C	25~58	25~58	25~58	25~58
Compressor	Brand		Mitsubishi	Mitsubishi	Mitsubishi	Mitsubishi
	Type		DC inverter	DC inverter	DC inverter	DC inverter
Refrigerant	Type/Quantity		R410A/3.0kg	R410A/3.0kg	R410A/3.8kg	R410A/3.8kg
	Fan Airflow	m ³ /h	5500	5500	5500	5500
Dimensions	Net	mm	1100x528x870	1100x528x870	1100x528x870	1100x528x870
	Packing	mm	1140x540x965	1140x540x965	1140x540x965	1140x540x965
Weight	Net/Packing	kg	85/97	85/97	91/104	91/104
	Sound Pressure Level	dB	57	57	59	59
Sound level	Sound Power Level	dB	67	67	69	69
	Max Length for VRF IDU	m	<100	<100	<100	<100
Pipe dimensions	Max Height for VRF IDU	m	<30	<30	<30	<30
	Max length for hydro kit	m	<30	<30	<30	<30
	Max height level for hydro kit	m	<30	<30	<30	<30
	Max height between IDUs	m	8	8	8	8
Connection pipe (liquid/gas)	Air conditioner side	mm	9.52/15.88	9.52/15.88	9.52/15.88	9.52/15.88
	Hydronic module side	mm	9.52/15.88	9.52/15.88	9.52/15.88	9.52/15.88
Water primary circuit waterflow	L/min	26.2	32.7	40.1	45.8	
Max indoor units combination	number	5	6	7	8	
Max simultaneity	%	Max 130% of outdoor unit capacity				

Hydronic module		CE-SLMK-100N-DS-001	CE-SLMK-160N-DS-003
Power Supply		220~240V/1N/50Hz	220~240V/1N/50Hz
Performance Data			
Leaving water temperature	Space heating	°C	25~60
	Domestic hot water	°C	40~60
Max. power input	kW	3.6	3.6
Max. current input	A	17	17
Sound power level	dB(A)	45	40
Dimension (W×H×D)	mm	490x910x340	490x910x340
Packing (W×H×D)	mm	620x1105x425	620x1105x425
Net/gross weight		kg	5
		kg	48/56
Water circuit	Piping connection ^(outlet/return)	mm	DN32/DN32
	Safety valve	kPa	600
	Drainage pipe	mm	DN20
	Heat exchanger/volume	L	Plate type/0.658
	Water pump/pump head	m	DC/9
Expansion tank	Volume	L	2
	Max. water pressure	kPa	800
Refrigerant circuit	Pre pressure	kPa	150
	Liquid side/Gas side	mm	Φ9.52/Φ15.88
Back-up E-heater	Power supply	V/N/Hz	230/1/50
	Capacity	kW	3kW



8/10/12.5/14/16kW

12.5/14/16/18kW

20/22.4kW

26/28/33.5kW

Long Refrigerant Piping

The total pipe length	100m(8-22.4kW),120m(26-33.5kW)
The longest pipe length	Actual length 60m Equivalent length 70m
Equivalent length from first indoor distributor to last indoor unit	20m
Height difference between indoor and outdoor unit:	Outdoor unit above≤20m Outdoor unit below≤30m
Height difference between indoor units	8m

*Please refer to the installation manual for detailed length description.

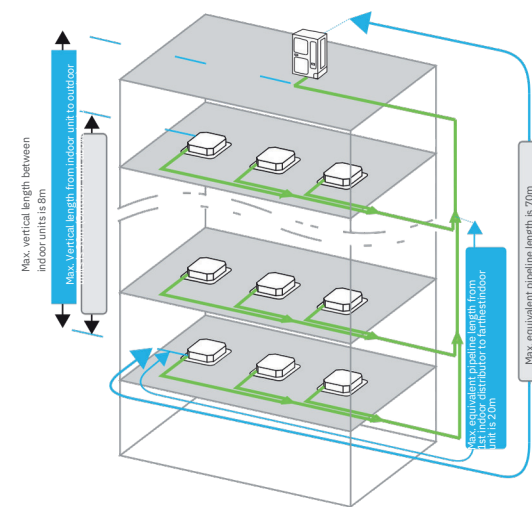

High Efficiency DC Inverter Compressor

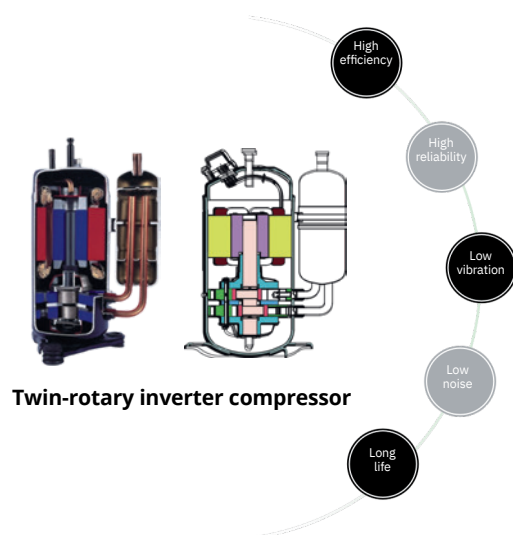

- Twin-rotary DC inverter compressor**
- Use high efficiency and reliability compressor
 - Has very good efficiency in part load condition
- High Efficiency, Low Noise**
- Optimized the efficiency and noise during operation with the latest technology.
- Environmental Protection**
- Developed the compressor with alternative refrigerant which can protect environment.
- Low Vibration**
- Reduced the vibration during compressor start and operation by using 2CYL Structure, simplified the match of air-conditioning.

High Efficiency DC Motor



- ◆ High efficiency DC fan motor
- ◆ Low noise and high efficiency because of high-density wire winding engineering
- ◆ Brushless with built-in sensor

Space Saving Installation

- Multiple indoor units can be connected to 1 outdoor unit, and long piping connection is also possible.
- Compare to one-drive-one type, the outdoor unit can be installed in various places to realize the space-saving installation.

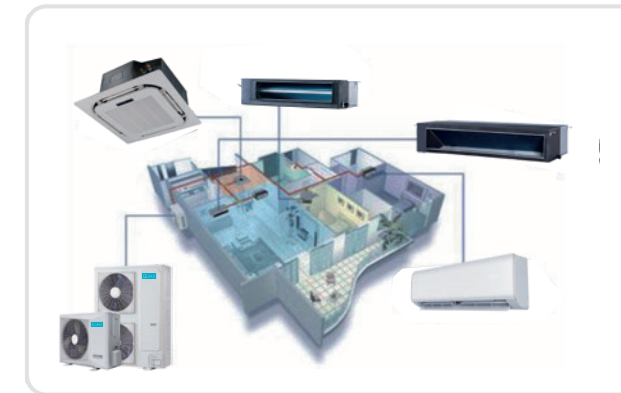

180° Sine Wave Control

The perfect combination of 180° Sine wave rotor frequency drive control technology and excellent IPM inverters, reduces the reactive loss of motor-driven, increases motor efficiency by 12%.

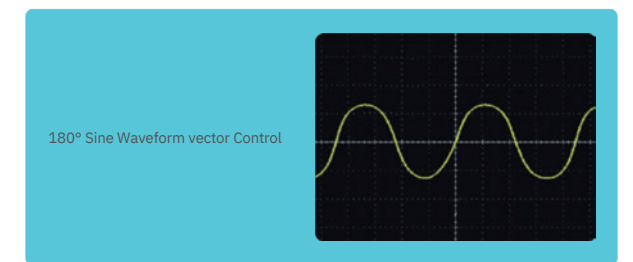
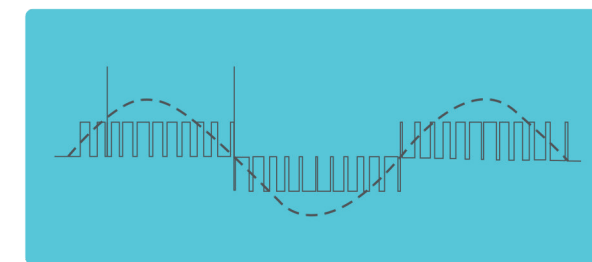

Increase efficiency by 12%

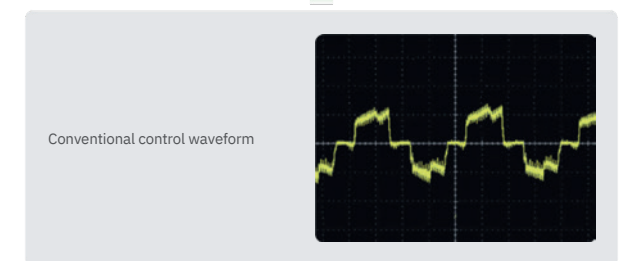
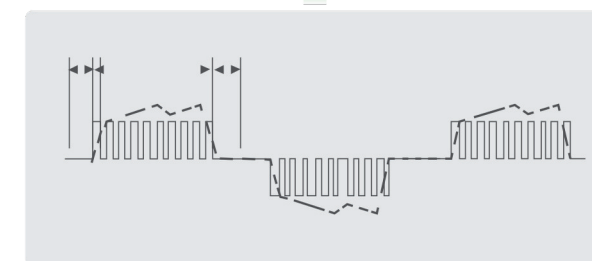

FEATURES

Low Noise

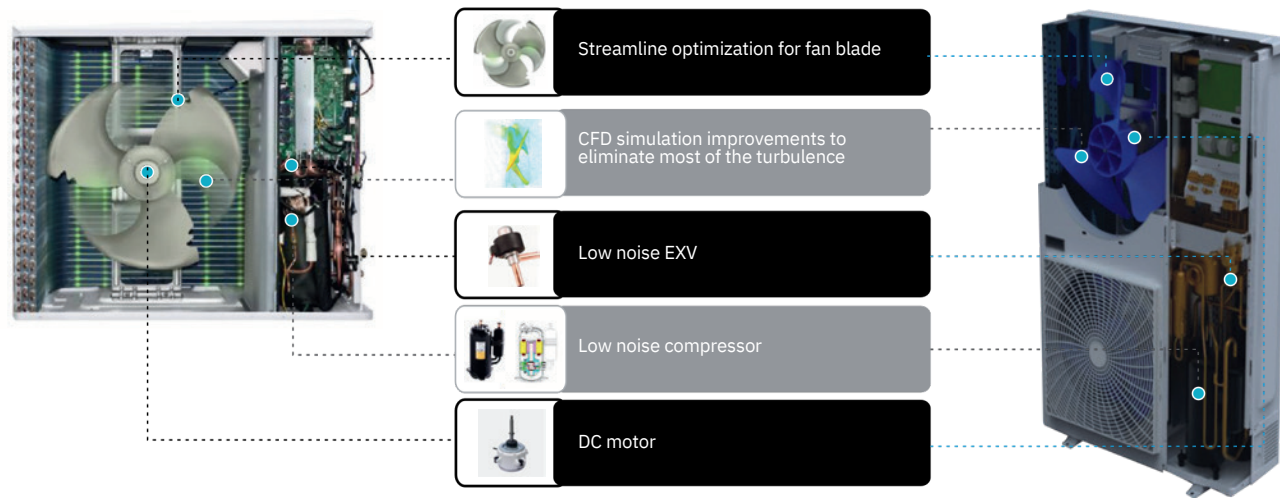

Wide Outdoor Operation Range

Max. cooling operating temperature is designed up to 55°C. Heating operating temperature is down to -20°C.

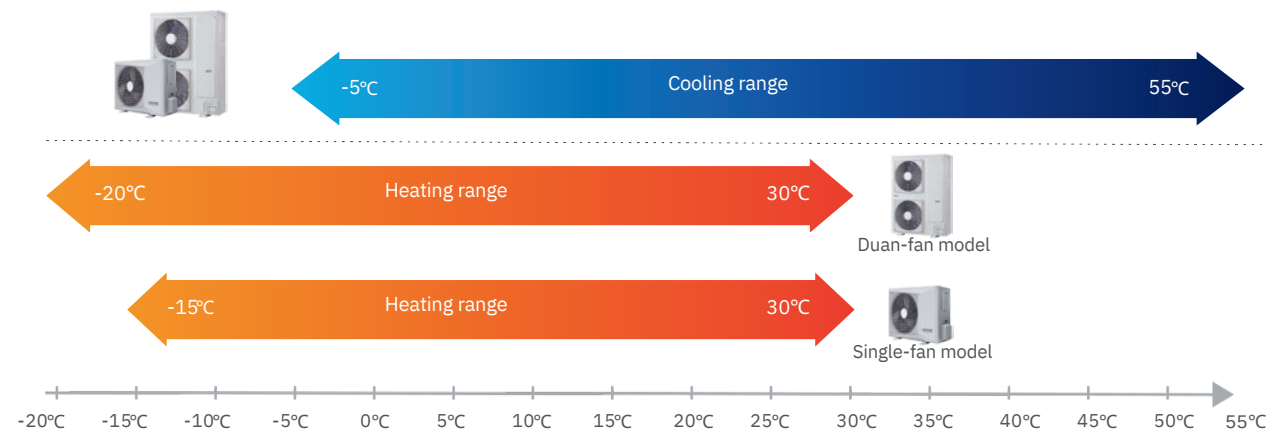

Intelligent Defrosting Program

Program starts only when unit needs to. Whereas conventional unit's defrosting timing & duration is fixed, causing fluctuations in temperature and personal comfort.

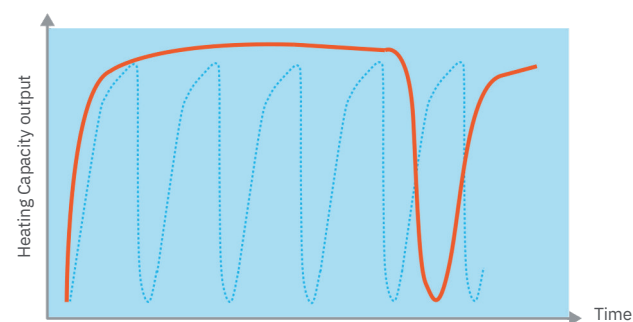

— Intelligent defrosting program
 Conventional program

Defrost curve

- Conventional unit's defrosting timing & duration is fixed. Intelligent defrosting program starts according to heat exchanging efficiency & capacity change due to the frost.
- Less temperature fluctuations, people feel more comfortable.

FEATURES

Fan Reversal Protection

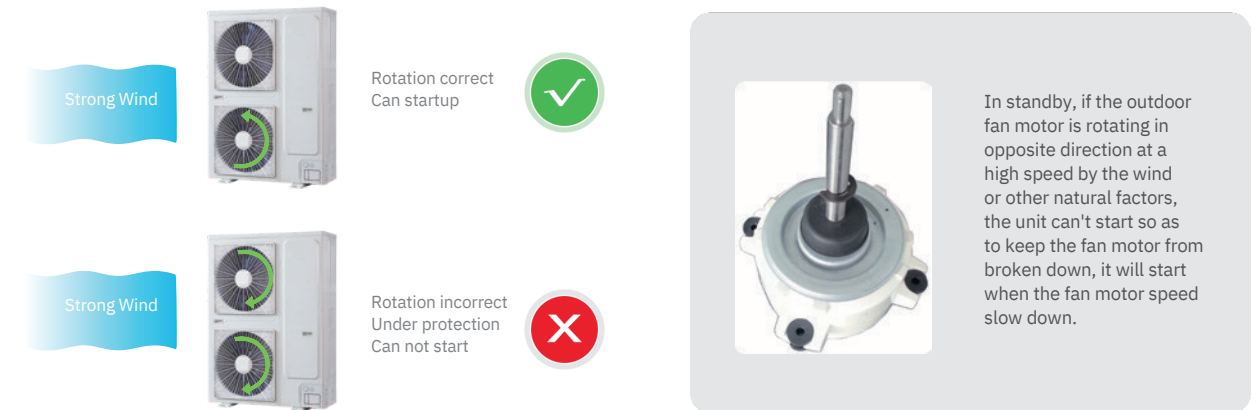

Mode Restriction

- 7 kinds of mode restriction:
 - Auto priority (Default Setting)
 - Cooling priority mode
 - Heating priority mode
 - First start mode
 - Cooling only mode
 - Heating only mode
 - VIP unit priority + AUTO priority mode
- Mode restriction function can be selected on the outdoor PCB.

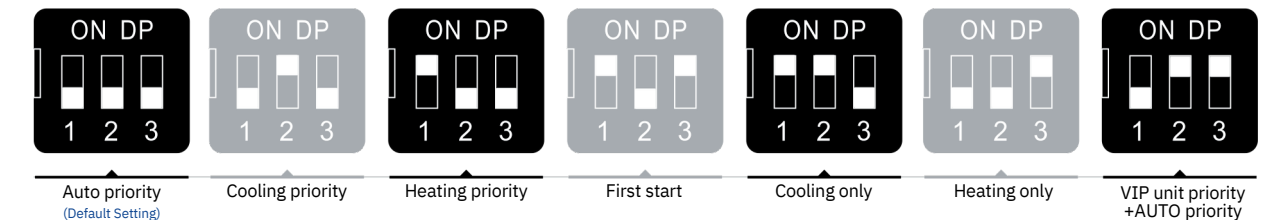

High Efficiency

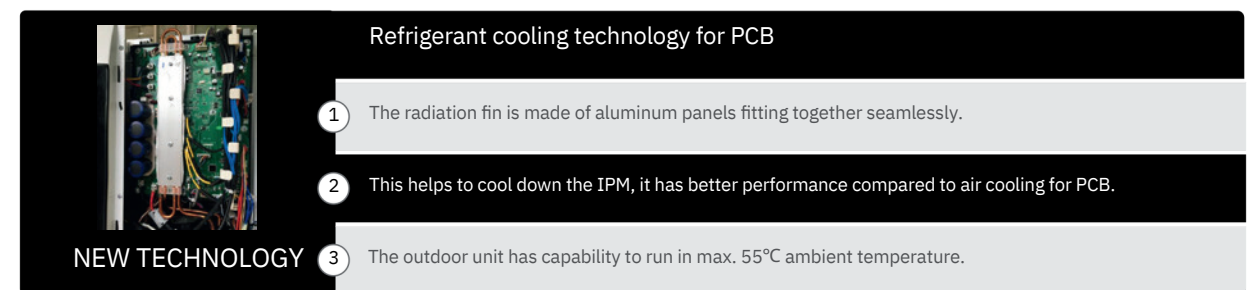

FEATURES

Automatically Addressing

- Automatically addressing: system will distribute address to indoor unit automatically.
- Automatic addressing will reduce artificial faults and manual works.

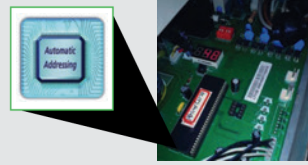

Independent Display Board

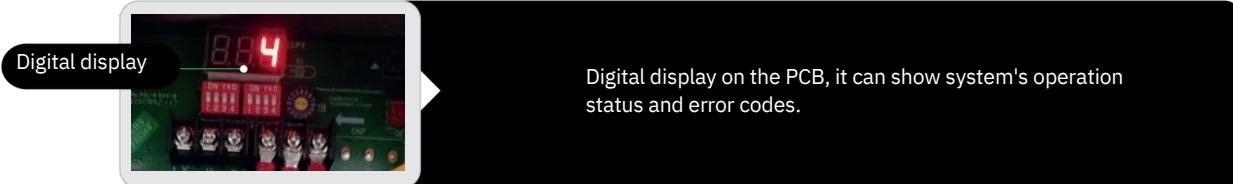

Service Window

- Service window on the right side to connect the cable and digital display to check the running data.
- One button to start the system to do the running test.

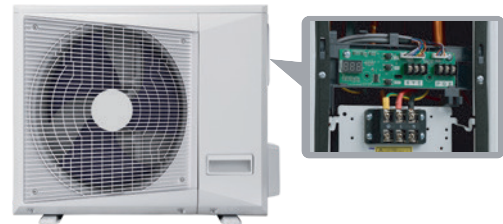

Refrigerant cooling tech. for PCB

- Good performance with enhanced refrigerant cooling solution
- Intelligent refrigerant control technology to protect PCB
- Quick action speed to make the main PCB working at suitable temperature range
- High reliability

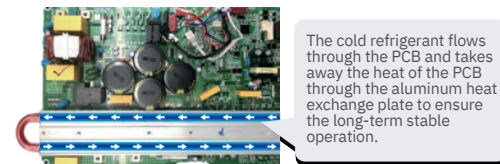

SPECIFICATION

Dual-fan

Model name	Power type (V/N/Hz)	Cooling				Heating				Compressor Type	Qty	Motor Type	Qty	Refrigerant Type	Volume (kg)	Sound pressure Level (DB(A))	Dimension (WxHxD)		Weight		Connecting		Max connected indoor units quantity
		Capacity (kW/Btu/h)	Power input (kW)	EER	COP	Capacity (kW/Btu/h)	Power input (kW)	Packing (mm)	Body (mm)								Net (kg)	Gross (kg)	Gas (mm)	Liquid (mm)			
MCHV-D125W/HZR1-050D	380-415/3/50	12.5	42000	3.38	3.70	14	47000	3.26	4.29	DC/Twin-rotary	1	DC/fan motor	2	R410a	3.45	56	1010x1445x415	975x1335x400	86.6	96.4	φ15.88		7
MCHV-D140W/HZR1-050D	380-415/3/50	14	47800	3.80	3.68	16	54000	3.97	4.03								3.8	8					
MCHV-D160W/HZR1-050D	380-415/3/50	16	54000	4.53	3.53	18	61000	4.61	3.91								3.8	9					
MCHV-D180W/HZR1-050D	380-415/3/50	18	61000	5.18	3.47	20	68000	5.02	3.98								4.2	10					
MCHV-D200W/HZR1-080	380-415/3/50	20	68200	5.92	3.38	22	75000	5.35	4.11								5.3	11					
MCHV-D224W/HZR1-080	380-415/3/50	22.4	76400	6.75	3.32	24	81800	5.62	4.27								5.3	13					
MCHV-D260W/HZR1-100	380-415/3/50	26	88700	7.54	3.45	28.5	97200	6.77	4.21								6.1	15					
MCHV-D280W/HZR1-100	380-415/3/50	28	95500	8.31	3.37	31.5	107500	8.18	3.85								8.0	16					
MCHV-D335W/HZR1-100	380-415/3/50	33.5	114300	9.46	3.54	37.5	128000	8.99	4.17								8.0	19					

Note
 1. Cooling Operation Conditions: Indoor Air Inlet Temperature: 27°C DB / 19°C WB, T1: Outdoor Air Inlet Temperature: 35°C DB
 2. Heating Operation Conditions: Indoor Air Inlet Temperature: 20.0°C DB, Outdoor Air Inlet Temperature: 7°C DB / 6°C WB

Single-fan

Model name	MCHV-DH080 W/R1	MCHV-DH100 W/R1	MCHV-D125 W/HZR1-D01	MCHV-D125 W/HZR1-D01	MCHV-D140 W/HZR1-F01	MCHV-D140 W/HZR1-F01	MCHV-D160 W/HZR1-F01	MCHV-D160 W/HZR1-
Power supply	220~240V/1N/50Hz	220~240V/1N/50Hz	220~240V/1N/50Hz	380~415V/3N/50Hz	220~240V/1N/50Hz	380~415V/3N/50Hz	220~240V/1N/50Hz	380~415V/3N/50Hz

Performance data		MCHV-DH080 W/R1	MCHV-DH100 W/R1	MCHV-D125 W/HZR1-D01	MCHV-D125 W/HZR1-D01	MCHV-D140 W/HZR1-F01	MCHV-D140 W/HZR1-F01	MCHV-D160 W/HZR1-F01	MCHV-D160 W/HZR1-
Cooling	Capacity	8.0	10.0	12.5	12.5	14.0	14.0	16.0	16.0
	Power input	2.60	3.00	4.19	3.20	4.63	3.75	5.3	4.75
	Rated current	11.8	13.6	14.5	6.0	17.0	7.0	6	8.8
	EER	3.08	3.33	2.98	3.91	3.02	3.73	2.98	3.37
Heating	Capacity	9.0	11.0	14.0	14.0	16.0	16.0	17.5	17.0
	Power input	2.65	3.10	3.52	3.52	4.00	4.00	4.4	4.4
	Rated current	12.0	14.0	16.0	6.6	18.2	7.5	20.0	8.2
	COP	3.40	3.55	3.98	3.98	4.00	4.00	3.98	3.86
COMPRESSOR DATA									
DC Inverter compressor	Quantity	1	1	1	1	1	1	1	1
	Type	Twin-rotary	Twin-rotary	Twin-rotary	Twin-rotary	Twin-rotary	Twin-rotary	Twin-rotary	Twin-rotary
	Brand	Mitsubishi	GMCC	Highly	Highly	Highly	Highly	Mitsubishi	Mitsubishi
Fan data									
Fan motor	Type	DC	DC	DC	DC	DC	DC	DC	DC
	Quantity	1	1	1	1	1	1	1	1
	Power output	75	90	90	90	220	170	220	170
Fan blade	Fan Quantity	1	1	1	1	1	1	1	1
	Air flow	3300	4000	4000	4000	5500	5500	5500	5500
Physical data									
Outdoor coil	Fin type	Hydrophilic Foil	Hydrophilic Foil	Hydrophilic Foil	Hydrophilic Foil	Hydrophilic Foil	Hydrophilic Foil	Hydrophilic Foil	Hydrophilic Foil
	Number of rows	3	2	2.5 Inner-grooved	2.5	3.0 Inner-grooved	3	3	3
	Tube type	Inner-grooved copper tube	Inner-grooved copper tube	grooved copper tube	Inner-grooved copper tube	grooved copper tube	Inner-grooved copper tube	Inner-grooved copper tube	Inner-grooved copper tube
Refrigerant	Type	R410a	R410a	R410a	R410a	R410a	R410a	R410a	R410a
	Volume	2.00	2.60	3.40	3.00	3.8	3.45	3.8	3.80
Dimension (WxHxD)	Net	935x702x383	1032x810x445	1032x810x445	1032x810x445	1100x870x528	1100x870x528	1100x870x528	1100x870x528
	Packing	975x770x420	1075x875x495	1075x875x495	1075x875x495	1140x965x540	1140x965x540	1140x965x540	1140x965x540
Weight	Net	47	60	72.5	67.4	88.5	87.5	90	90
	Gross	50	65	78	72.2	102.5	97.4	104	100
ODU sound level		≤54	≤56	≤58	≤56	59	≤57	59	≤57
Operation temp. range									
Cooling	Outdoor side	-5~55	-5~55	-5~55	-5~55	-5~55	-5~55	-5~55	-5~55
	Heating	-15~30	-15~30	-15~30	-15~30	-15~30	-15~30	-15~30	-15~30

Note
 1. The cooling conditions: indoor temp.: 27°C DB (80.6°F), 19°C WB (60°F), outdoor temp.: 35°C DB (95°F) equivalent pipe length: 5m drop length: 0m. 2. The heating conditions: indoor temp.: 20°C DB (68°F), 15°C WB (44.6°F), outdoor temp.: 7°C DB (44.8°F) equivalent pipe length: 5m drop length: 0m. 3. Sound level: Anechoic chamber conversion value, one measured point is 1 m in front of the unit at a height of 1 m. Two measured points are 1 m beside the unit at a height of 1 m. During actual operation, these values are normally somewhat higher as a result of ambient conditions. 4. The above data may be changed without notice for future improvement on quality at performance.

INDOOR UNITS

Provide you with fresh air



INDOOR UNITS LINE UP

Capacity (kW)	1-way cassette	2-way cassette	Round flow cassette	4-way cassette (Compact type)	Air Handler
2.2	•			•	
2.8	•			•	
3.6	•			•	
4.5	•	•		•	
5.6	•	•	•		
7.1	•	•	•		•
8.0		•	•		
9.0			•		
10.0			•		•
11.2			•		
12.0					
12.5			•		
14.0			•		
15.0					
16.0			•		•

Capacity (kW)	Wall-mounted	Floor Ceiling	Short ceiling concealed ducted unit	Medium ESP ducted unit	High ESP ducted unit	Fresh air processor
2.2	•		•			
2.8	•		•			
3.6	•	•	•			
4.5	•	•	•			
5.6	•	•	•			
7.1	•	•	•	•	•	
8.0		•		•	•	
9.0		•		•	•	
10.0				•	•	
11.2		•			•	
12.0				•	•	
14.0		•				•
15.0				•	•	
16.0		•				
20.0					•	
22.4						•
25.0					•	•
28.0					•	•
45.0					•	•
56.0					•	•

1-WAY CASSETTE

2-WAY CASSETTE



Accessories

Plenum box	Air filter	EXV	Drain pump	AC motor	DC motor
/	Standard	Standard	Standard(built-in)	Standard	/

Accessories

Plenum box	Air filter	EXV	Drain pump	AC motor	DC motor
/	Standard	Standard(built-in)	Standard(built-in)	Standard	/

✂ Slim body, easy to install

Has slim body with 250mm height, it is specially suitable for low suspended ceiling rooms.

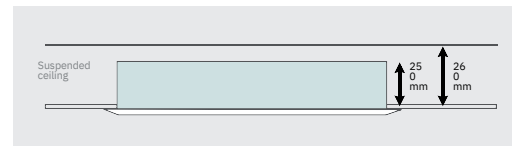

🔥 Built-in with drainage pump

Built-in with low noise long life drainage pump, Pumping head is 700mm, flexible for drainage pipe design.

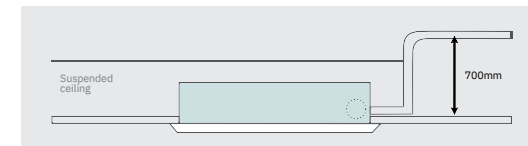

🌀 2 way air direction

Two direction air flow, flexibly install in various rooms or hallway

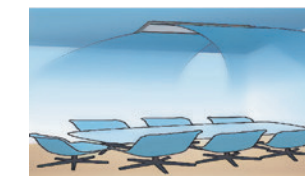

🔥 Built-in with drainage pump

Built-in with low noise long life drainage pump, Pumping head is 700mm, flexible for drainage pipe design.

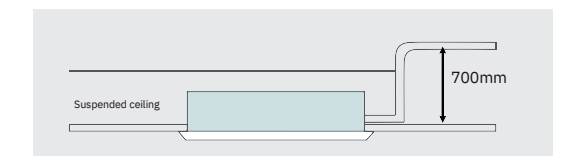

Model name	Power type	Capacity				Motor input	Air flow	Sound Level	ESP	Dimension(WxHxD)				Body Weight		Connecting pipe			Standard controller		
		Cooling		Heating						Packing	Body	Panel packing	Panel	Net	Gross	Gas	Liquid	Drain			
		kW	kBtu/h	kW	kBtu/h	kW	M3/h	CFM	DB(A)	Pa	mm	mm	mm	mm	kg	kg	mm	mm	mm		
MCHV-V22CA/HR1-Q101	50Hz	2.2	7.5	2.5	8.5																
MCHV-V28CA/HR1-Q101	50Hz	2.8	9.5	3.2	10.9	0.04	520	306	32~36		1150 x 275 x 645	985 x 250 x 513	1090 x 65 x 540	1070 x 50 x 520	24/3.6	28/5.0	Φ9.53				
MCHV-V36CA/HR1-Q101	50Hz	3.6	12.2	4.0	13.6																
MCHV-V45CA/HR1-Q103	50Hz	4.5	15.3	5.0	17.0	0.05	610	360	36~41	/	1460 x 305 x 680	1295 x 290 x 553	1405 x 70 x 575	1380 x 50 x 560	35.5/5	40/7	Φ12.7	Φ6.35	ODΦ25	Remote controller	
MCHV-V56CA/HR1-Q103	50Hz	5.6	19.1	6.3	21.4	0.07	750	440	35~41												
MCHV-V71CA/HR1-Q103	50Hz	7.1	24.2	8.0	27.2	0.09	950	550	38~45												

Notes:
 1. Power supply: 220~240V/1N for 50Hz, the above data is for AC motor model.
 2. Cooling test condition: indoor side 27°C DB, 19°C WB outdoor side 35°C DB. Heating test condition: indoor side 20°C DB, 15°C WB outdoor side 7°C DB.
 3. Sound level: measured at a point 1.4 m below the unit. During actual operation, these values are normally somewhat higher as a result of ambient conditions.
 4. The above data may be changed without notice for future improvement on quality and performance.

Model name	Power type	Capacity				Motor input	Air flow	Sound Level	ESP	Dimension(WxHxD)				Body Weight		Connecting pipe			Standard controller		
		Cooling		Heating						Packing	Body	Panel packing	Panel	Net	Gross	Gas	Liquid	Drain			
		kW	kBtu/h	kW	kBtu/h	kW	M3/h	CFM	DB(A)	Pa	mm	mm	mm	mm	kg	kg	mm	mm	mm		
MCHV-V45CA/HR1-Q202	50Hz	4.5	15.3	5.0	17	0.07	800	470	36~42		1215 x 360 x 630	1092 x 315 x 548	1205 x 75 x 655	1178 x 44 x 630	36/5	41/7	Φ12.7	Φ6.35			
MCHV-V56CA/HR1-Q202	50Hz	5.6	19.1	6.3	21.4					/											
MCHV-V71CA/HR1-Q203	50Hz	7.1	24.2	8.0	27.2	0.10	1120	650	40~46		1455 x 360 x 630	1332 x 315 x 548	1445 x 75 x 655	1420 x 44 x 630	48/6	42.5/8.5	Φ15.9	Φ9.53	ODΦ25	Remote controller	
MCHV-V80CA/HR1-Q203	50Hz	8.0	27.2	9.0	30.7																

Notes:
 1. Power supply: 220~240V/1N for 50Hz, the above data is for AC motor model.
 2. Cooling test condition: indoor side 27°C DB, 19°C WB outdoor side 35°C DB. Heating test condition: indoor side 20°C DB, 15°C WB outdoor side 7°C DB.
 3. Sound level: measured at a point 1.4 m below the unit. During actual operation, these values are normally somewhat higher as a result of ambient conditions.
 4. The above data may be changed without notice for future improvement on quality and performance.



Accessories

Plenum box	Air filter	EXV	Drain pump	AC motor	DC motor
/	Standard	Standard	Standard(built-in)	Standard	Optional

Wide air delivering

Airflow is soft and smooth, air can be delivered to every corner without dead angle, it makes the room temperature distribution more balance.

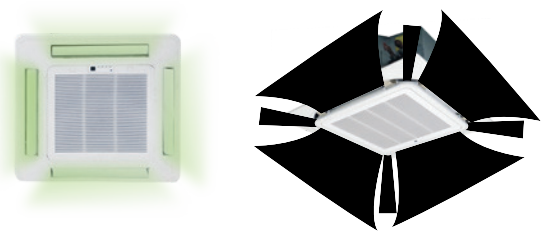

Space saving installation

it has a slim body with 230mm height, it is specially suitable for low suspended ceiling rooms. (5.6~8.0kW)

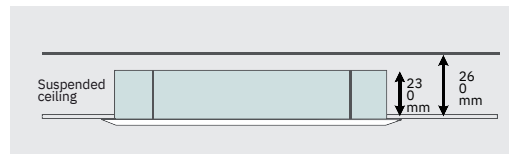

Fresh air intake

Four interfaces to connect with duct to another room. Fresh air intake, aims to provide more healthy and comfortable indoor environment.

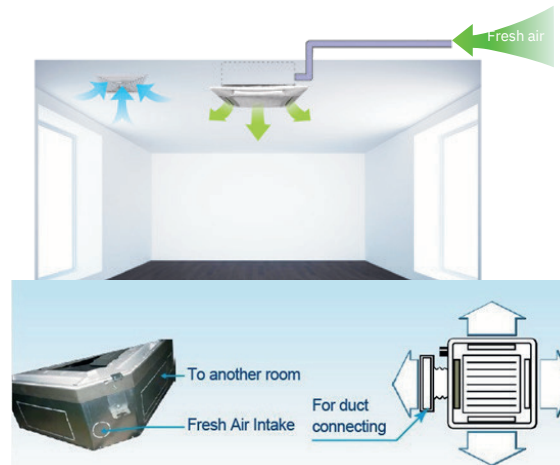

Built-in with drainage pump

Built-in with low noise long life drainage pump, Pumping head is 1200mm, flexible for drainage pipe design.

Note: The pumping head of 4-way cassette unit (compact type) is 700mm.

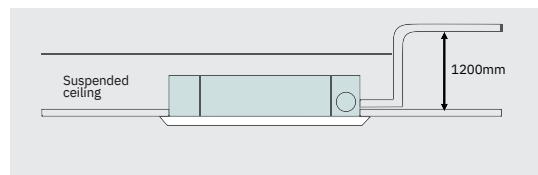

4-way Cassette Unit(Compact type)

Model name	Power type	Capacity				Power input	Air flow		Sound Level	ESP	Dimension(WxHxD)				Body Weight		Connecting pipe			Standard controller						
		Cooling kW	Cooling kBTu/h	Heating kW	Heating kBTu/h		M ³ /h	CFM			Packing mm	Body mm	Panel packing mm	Panel mm	Net kg	Gross kg	Gas mm	Liquid mm	Drain mm							
MCMV-V22Q4/HR1-C	50Hz	2.2	7.5	2.5	8.5	0.038	447	263	22-34	/	755 x 375 x 680	653 x 267 x 585	750 x 95 x 750	650 x 30 x 650	17.5	23	Φ6.35	ODΦ25	Remote controller							
MCMV-V22Q4/HNR1-C	60Hz																									
MCMV-V28Q4/HR1-C	50Hz	2.8	9.5	3.2	10.9	0.038	447	263	22-34													17.5	23			
MCMV-V28Q4/HNR1-C	60Hz																									
MCMV-V36Q4/HR1-C	50Hz	3.6	12.2	4.0	13.6	0.040	515	303	27-38													17.5	23			
MCMV-V36Q4/HNR1-C	60Hz																									
MCMV-V45Q4/HR1-C	50Hz	4.5	15.3	5.0	17	0.040	515	303	27-38													17.5	23			
MCMV-V45Q4/HNR1-C	60Hz																									

Round-flow Cassette

Model name	Power type	Capacity				Power input	Air flow		Sound Level	ESP	Dimension(WxHxD)				Body Weight		Connecting pipe			Standard controller					
		Cooling kW	Cooling kBTu/h	Heating kW	Heating kBTu/h		M ³ /h	CFM			Packing mm	Body mm	Panel packing mm	Panel mm	Net kg	Gross kg	Gas mm	Liquid mm	Drain mm						
MCMV-V56QR/HR1	50Hz	5.6	19.1	6.3	21.4	0.043	860	500	32-39	/	920 x 265 x 985	833 x 232 x 900	1030 x 100 x 1030	24	30	Φ12.7	Φ6.35	Remote controller							
MCMV-V56QR/HNR1	60Hz																								
MCMV-V71QR/HR1	50Hz	7.1	24.2	8.0	27.2	0.093	1200	700	35-39												24	30			
MCMV-V71QR/HNR1	60Hz																								
MCMV-V80QR/HR1	50Hz	8.0	27.2	8.8	30	0.160	1400	820	37-41												24	30			
MCMV-V80QR/HNR1	60Hz																								
MCMV-V90QR/HR1	50Hz	9.0	30.7	10.0	34.1	0.160	1400	820	37-41												28.5	35			
MCMV-V90QR/HNR1	60Hz																								
MCMV-V100QR/HR1	50Hz	10.0	34.1	11.0	37.5	0.160	1400	820	37-41					28.5	35	Φ15.88	Φ9.52	Remote controller							
MCMV-V100QR/HNR1	60Hz																								
MCMV-V112QR/HR1	50Hz	11.2	38.2	12.5	42.6	0.160	1400	820	37-41					28.5	35										
MCMV-V112QR/HNR1	60Hz																								
MCMV-V125QR/HR1	50Hz	12.5	42.6	14.0	47.7	0.160	1400	820	37-41					28.5	35										
MCMV-V125QR/HNR1	60Hz																								
MCMV-V140QR/HR1	50Hz	14.0	47.7	15.0	51.1	0.160	1800	1050	38-46					28.5	35										
MCMV-V140QR/HNR1	60Hz																								
MCMV-V160QR/HR1	50Hz	16.0	54.5	17.0	58	0.160	1800	1050	38-46					28.5	35										
MCMV-V160QR/HNR1	60Hz																								

Notes:

1. Power supply: 220-240V/1N for 50Hz; 208-230V/1N for 60Hz, the above data is for AC motor model.
2. Cooling test condition: indoor side 27°C DB, 19°C WB outdoor side 35°C DB. Heating test condition: indoor side 20°C DB, 15°C WB outdoor side 7°C DB.
3. Sound level: measured at a point 1.4 m below the unit. During actual operation, these values are normally somewhat higher as a result of ambient conditions.
4. The above data may be changed without notice for future improvement on quality and performance.

SHORT CEILING CONCEALED DUCTED UNIT

SPECIFICATION

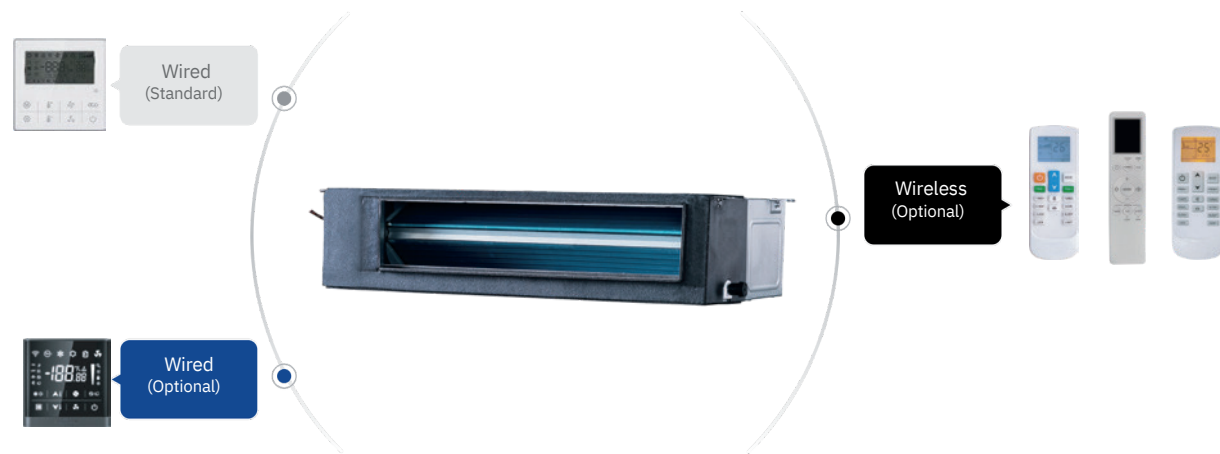

✂ Slim body, easy to install

Has slim body with 210mm height, it is specially suitable for low suspended ceiling rooms.

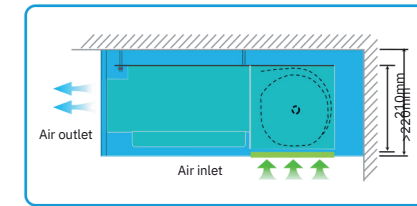

🌀 DC fan motor is optional

🚰 Drain pump is optional

Pumping head is 700mm.



Accessories

Plenum box	Air filter	EXV	Drain pump	AC motor	DC motor
Standard	Optional	Standard(built-in)	Optional	Standard	Optional

✂ Flexible installation

Air return method is optional by actual installation, from rear or from bottom.

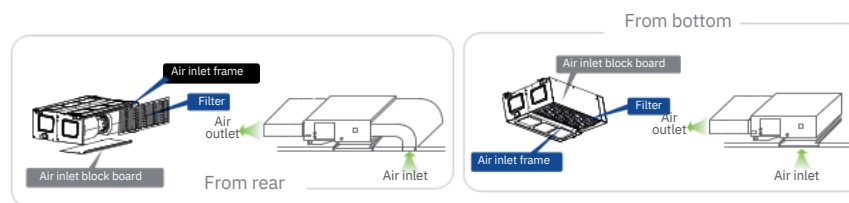

🌀 Big air flow and low noise

Big air flow low noise centrifugal fan blade with special air tunnel system, and the unique shock absorption measures, making this series ducted units' running noise is as low as 24 dB(A), let users to enjoy the comfort, sleep without any disturbance.

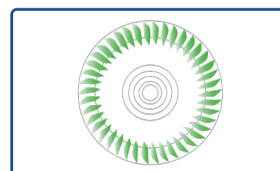
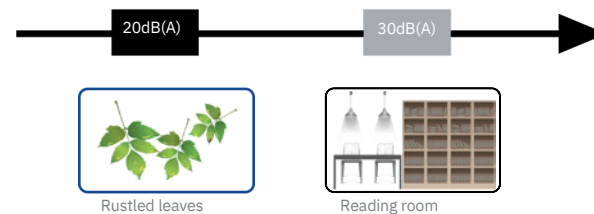

Special resin material fan wheel.



All vanes are dislocation distribution to offset soundwave, so that the noise can be reduced.



High efficiency low noise motor, motor and support frame with rubber ring isolation, can absorb vibration and reduce noise.

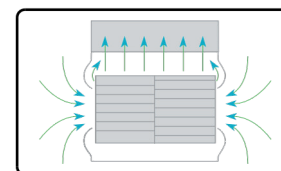

Air inlet of fan wheel casing is arch curved design; it can reduce air flow's disturbance, make if flow smoother to reduce noise.

Model name	Power type	Capacity				Rated input	Air flow		Sound Level	ESP	Dimension(WxHxD)				Body Weight		Connecting pipe			Standard controller
		Cooling kW	Heating kW	Cooling kBTu/h	Heating kBTu/h		M ³ /h	CFM			Packing mm	Body mm	Panel packing mm	Panel mm	Net kg	Gross kg	Gas mm	Liquid mm	Drain mm	
MCMV-V22TA/HR1-C	50Hz	2.2	7.5	2.5	8.5	0.08	450	260	24-29	30	910 x 240 x 510	814 x 210 x 467			17.5	20.0	Φ9.52			
MCMV-V22TA/HNR1-C	60Hz																			
MCMV-V28TA/HR1-C	50Hz	2.8	9.5	3.2	10.9	0.11	550	324	25-32		18.0	20.5	Φ6.35							
MCMV-V28TA/HNR1-C	60Hz																			
MCMV-V36TA/HR1-C	50Hz	3.6	12.2	4.0	13.6	0.11	620	360	32-37		18.0	20.5	Φ12.7							
MCMV-V36TA/HNR1-C	60Hz																			
MCMV-V45TA/HR1-C	50Hz	4.5	15.3	5.0	17	0.16	800	520	28-38		21.5	24.5								
MCMV-V45TA/HNR1-C	60Hz																			
MCMV-V56TA/HR1-C	50Hz	5.6	19.1	6.3	21.4	0.18	1000	640	30-39		26.5	30.0	Φ15.88	Φ9.52						
MCMV-V56TA/HNR1-C	60Hz																			
MCMV-V71TA/HR1-C	50Hz	7.1	24.2	8.0	27.2	0.18	1000	640	30-39	26.5	30.0	Φ15.88	Φ9.52							
MCMV-V71TA/HNR1-C	60Hz																			

Notes:

- Power supply: 220-240V/1N for 50Hz; 208-230V/1N for 60Hz, the above data is for AC motor model.
- Cooling test condition: indoor side 27°C DB, 19°C WB outdoor side 35°C DB. Heating test condition: indoor side 20°C DB, 15°C WB outdoor side 7°C DB.
- Sound level: measured at a point 1 m in front of the unit outlet and 1 m below the unit outlet center. During actual operation, these values are normally somewhat higher as a result of ambient conditions.
- The above data may be changed without notice for future improvement on quality and performance.

MEDIUM & FREE ESP DUCTED UNIT

SPECIFICATION

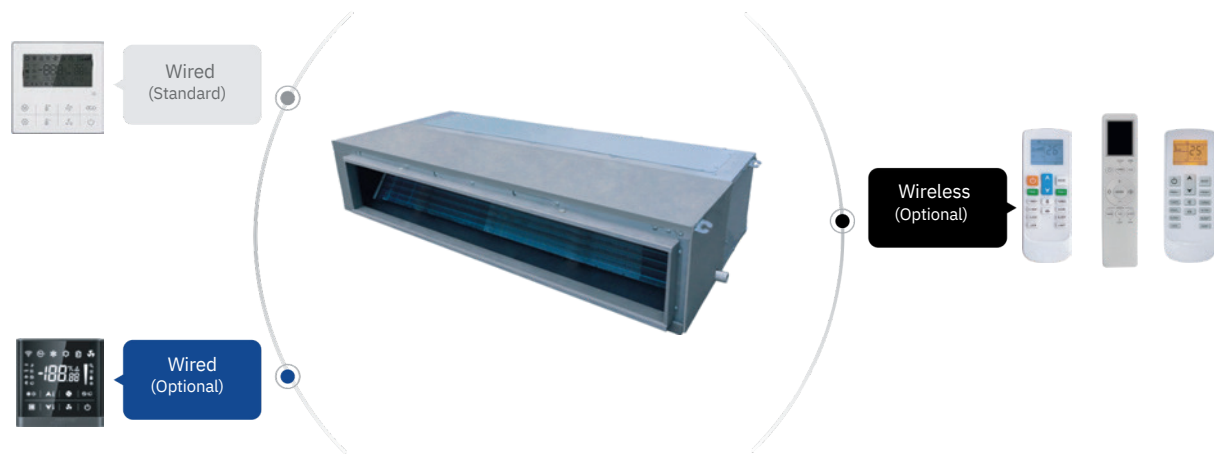

Accessories

Plenum box	Air filter	EXV	Drain pump	AC motor	DC motor
Standard	Standard	Standard	Optional	Standard	Optional

Static pressure

70Pa ESP is standard, suitable for long distance air supply, 30Pa is optional (can be set on site), suitable for low noise requirement rooms.

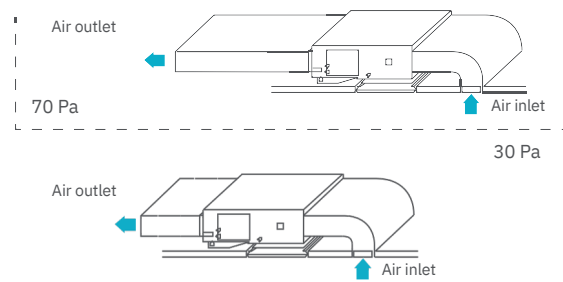

Fresh air intake

A reserved outside air intake port allows outdoor air to be introduced directly into the unit, no need for a separate ventilation system.

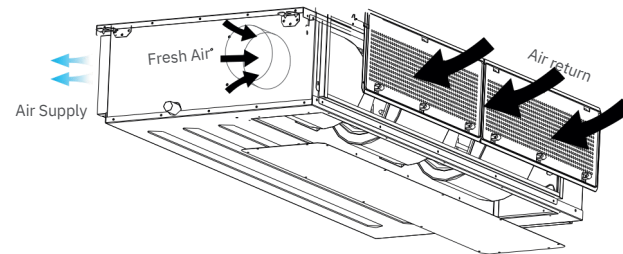

Convenient in drainage pipe installation

Reserved drainage pipe outlet holes on left side and right side, installer can choose the outlet holes on site as per actual conditions, flexible for drainage pipe installation.

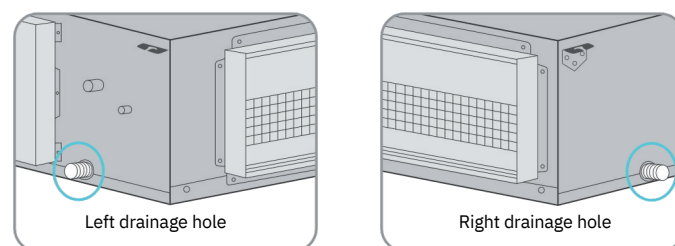

Low noise design

Using multiple noise reduction technology, including the design of high efficiency low noise motor, aviation fan wheel, low vibration wheel casing, unique design, the inner wall configuration with high quality insulation materials, and so on, to make the units running in a low noise condition.

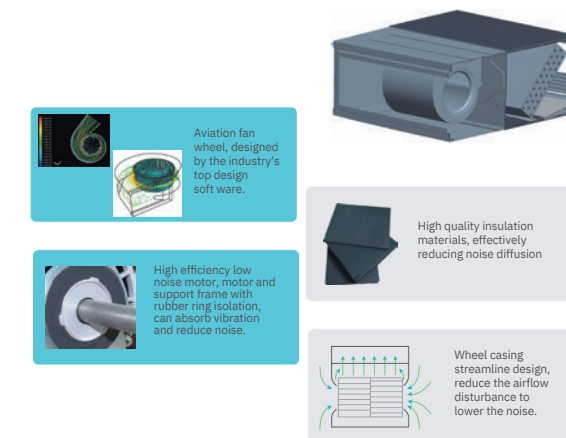

DC fan motor is optional

The power consumption of DC fan motor can be reduced greatly in comparison to corresponding AC type.

Flexible air return installation

Air return from rear or bottom is easy to change on site, convenient for installation.

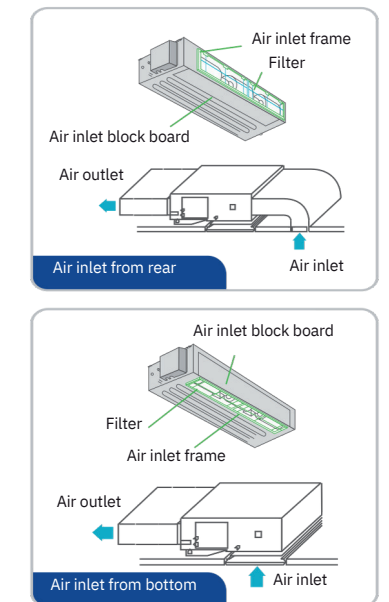

Model name	Power type	Capacity				Rated input	Air flow	Sound Level DB(A)	ESP	Dimension(WxHxD)		Body Weight		Connecting pipe			Standard controller	
		Cooling kW	Heating kW	Cooling kBTU/h	Heating kBTU/h					Packing mm	Body mm	Net kg	Gross kg	Gas mm	Liquid mm	Drain mm		
MCHV-D71TB/HR1-F2A3	50Hz	7.1	24.2	8.0	27.3	0.09	1200	702	33-37	1270 x 320 x 820	1200 x 267 x 740	31.0	37.5					
MCHV-D80TB/HR1-F2A3	50Hz	8.0	27.3	9.0	30.7	0.11	1350	790	34-49									
MCHV-D90TB/HR1-F2A3	50Hz	9.0	30.7	10.0	34.1	0.14	1450	848	34-41	1500 x 320 x 820	1437 x 267 x 740	32.0	39.0					
MCHV-D100TB/HR1-F2A3	50Hz	10.0	34.1	11.2	38.2	0.18	1850	1080	35-44									
MCHV-D112TB/HR1-F2A3	50Hz	11.2	38.2	12.5	42.7	0.27	2200	1287	38-48	1255 x 325 x 720	1209 x 260 x 680	33.0	37.0					
MCHV-D125TB/HR1-F2A5	50Hz	12.5	42.7	14.0	47.8	0.40	1850	1080	38-43									
MCHV-D140TB/HR1-F2A5	50Hz	14.0	48.5	16.0	54.6	0.40	1220	710	36-41	1490 x 325 x 720	1445 x 260 x 680	46.0	50.0					
MCHV-D150TB/HR1-F2A5	50Hz	15.0	54.6	17.0	58.0													2000
MCHV-D160TB/HR1-F2A5	50Hz	16.0	54.6	18.0	61.4	0.40	1850	1080	38-43	1255 x 325 x 720	1209 x 260 x 680	33.0	37.0					
MCMV-V71TB/HR1-B	50Hz	7.1	24.2	8.0	27.2													1850
MCMV-V71TB/HNR1-B	60Hz	7.1	24.2	8.0	27.2	0.40	1220	710	36-41	1490 x 325 x 720	1445 x 260 x 680	46.0	50.0					
MCMV-V80TB/HR1-B	50Hz	8.0	27.2	9.0	30.7													1850
MCMV-V80TB/HNR1-B	60Hz	8.0	27.2	9.0	30.7	0.40	1220	710	36-41	1490 x 325 x 720	1445 x 260 x 680	46.0	50.0					
MCMV-V90TB/HR1-B	50Hz	9.0	30.7	10.0	34.1													1850
MCMV-V90TB/HNR1-B	60Hz	9.0	30.7	10.0	34.1	0.40	1220	710	36-41	1490 x 325 x 720	1445 x 260 x 680	46.0	50.0					
MCMV-V100TB/HR1-B	50Hz	10.0	34.1	11.0	37.5													2000
MCMV-V100TB/HNR1-B	60Hz	10.0	34.1	11.0	37.5	0.40	1220	710	36-41	1490 x 325 x 720	1445 x 260 x 680	46.0	50.0					
MCMV-V120TB/HR1-B	50Hz	12.0	40.9	13.0	44.3													2000
MCMV-V120TB/HNR1-B	60Hz	12.0	40.9	13.0	44.3	0.40	1220	710	36-41	1490 x 325 x 720	1445 x 260 x 680	46.0	50.0					
MCMV-V150TB/HR1-B	50Hz	15.0	51.1	17.0	58													2200
MCHV-D71TH/HR1-F2A3	50/60Hz	7.1	24.2	8.0	27.3	0.13	1350	790	31-49	1255x330 x780	1200x267 x740	34.0	38.0					
MCHV-D80TH/HR1-F2A3	50/60Hz	8.0	27.3	9.0	30.7	0.13	1550	910	31-50									
MCHV-D90TH/HR1-F2A3	50/60Hz	9.0	30.7	10.0	34.1	0.16	1850	1100	34-51	1490x330 x780	1437x267 x740	40.0	44.0					
MCHV-D100TH/HR1-F2A5	50/60Hz	10.0	34.1	11.2	38.2	0.16	2200	1300	39-52									
MCHV-DTH125/HR1-F2A5	50/60Hz	12.5	42.7	14.0	47.8	0.22	1850	1100	34-51			41.5	45.5					
MCHV-DTH140/HR1-F2A5	50/60Hz	14.2	48.5	16.0	54.6	0.36	2200	1300	39-52									
MCHV-DTH160/HR1-F2A5	50/60Hz	16.0	54.6	18.0	61.4	0.36												

Notes:

- Power supply: 220-240V/1N for 50Hz; 208-230V/1N for 60Hz, the above data is for AC motor model.
- Cooling test condition: indoor side 27°C DB, 19°C WB outdoor side 35°C DB. Heating test condition: indoor side 20°C DB, 15°C WB outdoor side 7°C DB.
- Sound level: measured at a point 1 m in front of the unit outlet and 1 m below the unit outlet center. During actual operation, these values are normally somewhat higher as a result of ambient conditions.
- The above data may be changed without notice for future improvement on quality and performance.

HIGH ESP DUCTED UNIT

SPECIFICATION

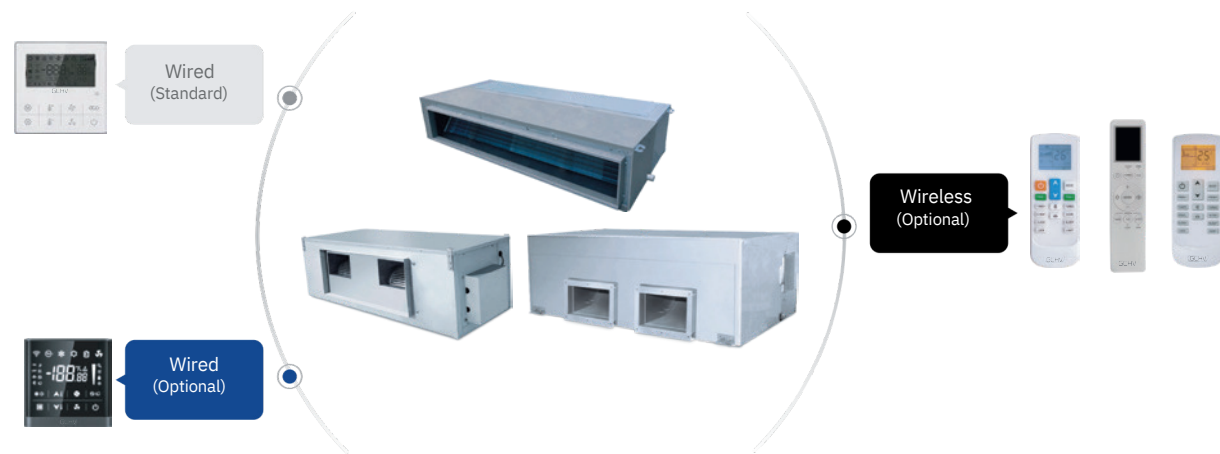

Accessories

Plenum box <small>Standard</small>	Air filter <small>Standard</small>	EXV <small>Standard</small>	Drain pump <small>Optional</small>	AC motor <small>Standard</small>	DC motor <small>/</small>
---------------------------------------	---------------------------------------	--------------------------------	---------------------------------------	-------------------------------------	------------------------------

Optional water pump

Slim body, saving suspended ceiling spaces. And water pump is optional, pump head up to 700mm

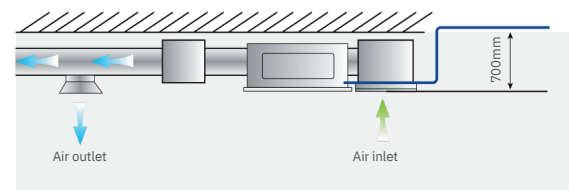

Can be used with various diffusers

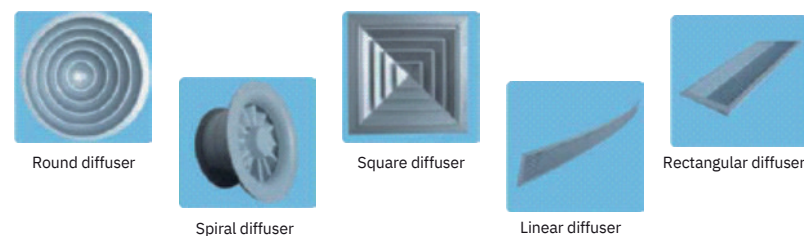

Used with various diffusers, meet for different kinds of decoration.

High static pressure

Big air flow with high static pressure, easy for large rooms duct design. Suitable for different shape of rooms.

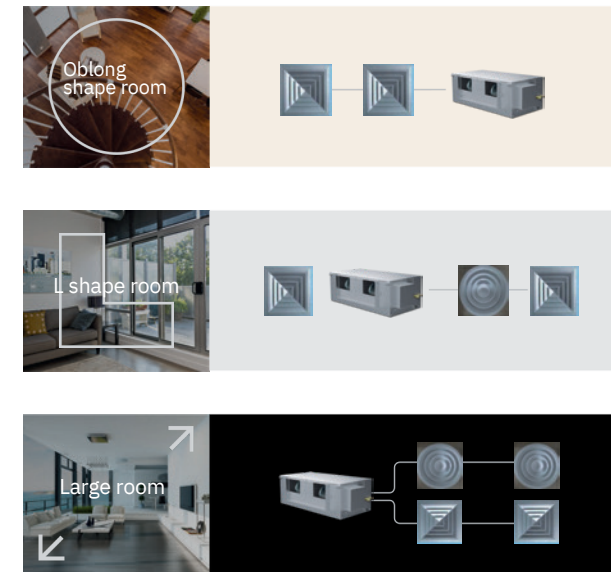

High static pressure ducted unit

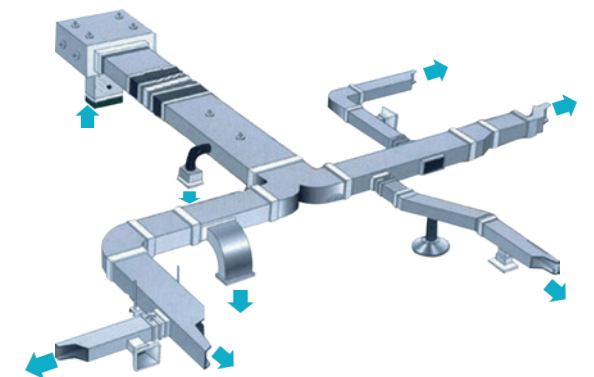

Long distance multi-point air supply

Model name	Power type	Capacity				Power input	Air flow	Sound level	ESP	Dimension(WxHxD)			Body Weight		Connecting pipe			Standard controller
		Cooling kW	Cooling kBTU/h	Heating kW	Heating kBTU/h					Packing mm	Body mm	Net kg	Gross kg	Gas. mm	Liquid mm	Drain mm		
MCMV-V71TH/HNR1-B	50Hz	7.1	24.2	7.8	26.6	0.40	1500	880	40-42	1490 x 325 x 720	1445 x 260 x 680	46	50	Ø15.88	Ø9.52	ODØ25	Wired controller	
MCMV-V71TH/HNR1-B	60Hz																	
MCMV-V80TH/HNR1-B	50Hz	8.0	27.2	8.8	30	0.50	2300	1350	44-52	1245 x 445 x 655	1190 x 370 x 620	47	51	Ø15.88	Ø9.52	ODØ25	Wired controller	
MCMV-V80TH/HNR1-B	60Hz																	
MCMV-V90TH/HNR1-B	50Hz	9.0	30.7	10.0	34.1	1.72	4000	2350	45-53	1510x580x870	1465x448x811	102	113	Ø22.2	Ø12.7	ODØ30	Wired controller	
MCMV-V90TH/HNR1-B	60Hz																	
MCMV-V100TH/HNR1-B	50Hz	10.0	34.1	11.0	37.5	1.30	4100	2400	48-52	1515x885x580	1440x811x448	100	110	Ø22.2	Ø12.7	ODØ30	Wired controller	
MCMV-V100TH/HNR1-B	60Hz																	
MCMV-V120TH/HNR1-B	50Hz	12.0	40.9	13.0	44.3	1.72	4400	2580	45-55	1510x580x870	1465x448x811	102	113	Ø22.2	Ø12.7	ODØ30	Wired controller	
MCMV-V120TH/HNR1-B	60Hz																	
MCMV-V150TH/HNR1-B	50Hz	15.0	51.1	17.0	58.0	1.30	4100	2400	48-52	1515x885x580	1440x811x448	100	110	Ø22.2	Ø12.7	ODØ30	Wired controller	
MCMV-V150TH/HNR1-B	60Hz																	
MCMV-V200TH/HNR1-B	50Hz	20.0	68.2	22.0	75.0	1.72	4400	2580	45-55	1510x580x870	1465x448x811	102	113	Ø22.2	Ø12.7	ODØ30	Wired controller	
MCMV-V200TH/HNR1-B	60Hz																	
MCHV-D200TH/HNR1-F310	50/60Hz	20.0	68.2	22.0	75.0	1.20	3750	2200	45-50	1515x885x580	1440x811x448	102	113	Ø22.2	Ø12.7	ODØ30	Wired controller	
MCHV-D200TH/HNR1-F310	60Hz																	
MCMV-V250TH/HNR1-B	50Hz	25.0	85.3	27.5	93.8	1.72	4200	2470	45-54	1510x580x870	1465x448x811	102	113	Ø22.2	Ø12.7	ODØ30	Wired controller	
MCMV-V250TH/HNR1-B	60Hz																	
MCHV-D250TH/HNR1-F310	50/60Hz	25.0	85.3	27.5	93.8	1.20	3750	2200	46-51	1515x885x580	1440x811x448	100	110	Ø22.2	Ø12.7	ODØ30	Wired controller	
MCHV-D250TH/HNR1-F310	60Hz																	
MCHV-V260TH/HNR1-F310	60Hz	26.0	88.7	28.6	97.6	1.62	4500	2650	45-55	1515x885x580	1440x811x448	100	110	Ø22.2	Ø12.7	ODØ30	Wired controller	
MCHV-V260TH/HNR1-F310	50Hz																	
MCMV-V280TH/HNR1-B	50Hz	28.0	95.5	30.8	105.0	1.72	4400	2580	45-55	1510x580x870	1465x448x811	102	113	Ø22.2	Ø12.7	ODØ30	Wired controller	
MCMV-V280TH/HNR1-B	60Hz																	
MCHV-D280TH/HNR1-F310	50/60Hz	28.0	95.5	30.8	105.0	1.30	4100	2400	48-52	1515x885x580	1440x811x448	100	110	Ø22.2	Ø12.7	ODØ30	Wired controller	
MCHV-D280TH/HNR1-F310	60Hz																	
MCMV-V450TH/HZR1-B	50Hz	45.0	153.5	50.0	170.6	2.60	6000	3520	60	200	2267 x 840 x 1050	2165 x 676 x 916	222	260	Ø28.6	Ø15.88	ODØ32	Wired controller
MCMV-V450TH/HZR1-B	60Hz																	
MCHV-V350TH/HXR1-F320	60Hz	35.0	120.0	38.5	130.0	1.93	7500	4400	63	250	2267 x 840 x 1050	2165 x 676 x 916	217	280	Ø28.6	Ø15.88	ODØ32	Wired controller
MCHV-V350TH/HXR1-F320	50Hz																	
MCMV-V560TH/HNR1-B	50Hz	56.0	191.0	63.0	214.9	3.40	8000	4700	64	200	2267 x 840 x 1050	2165 x 676 x 916	222	260	Ø28.6	Ø15.88	ODØ32	Wired controller
MCMV-V560TH/HNR1-B	60Hz																	
MCHV-V520TH/HXR1-F320	60Hz	52.0	175.0	57.2	195.0	3.60	10600	6235	67	250	2267 x 840 x 1050	2165 x 676 x 916	237	300	Ø28.6	Ø15.88	ODØ32	Wired controller
MCHV-V520TH/HXR1-F320	50Hz																	

Notes:

1. Power supply: 220~240V/1N for 50Hz; 208~230V/1N for 60Hz.
2. Cooling test condition: indoor side 27°C DB, 19°C WB outdoor side 35°C DB. Heating test condition: indoor side 20°C DB, 15°C WB outdoor side 7°C DB.
3. Sound level: measured at a point 1 m in front of the unit outlet and 1 m below the unit outlet center. During actual operation, these values are normally somewhat higher as a result of ambient conditions.
4. The above data may be changed without notice for future improvement on quality and performance.

WALL MOUNTED UNIT



SPECIFICATION

Model Power	MCHV-D22G /HR1-GSB	MCHV-D28G /HR1-GSB	MCHV-D36G /HR1-GSB	MCHV-D45G /HR1-GSB	MCHV-D56G /HR1-GSB	MCHV-D71G /HR1-GSB	MCHV-D71CG /HR1-GSD	MCHV-D80CG /HR1-GSD
Supply(V/N/Hz)	220-240/1/50&60	220-240/1/50&60	220-240/1/50&60	220-240/1/50&60	220-240/1/50&60	220-240/1/50&60	220-240/1/50	220-240/1/50
Capacity	Cooling	2.2	2.8	3.6	4.5	5.6	7.1	7.1
	Heating	2.5	3.2	4.0	5.0	6.3	8.0	8.0
Power input	15	15	18	20	23	35	35	35
Fan motor	Type	DC	DC	DC	DC	DC	DC	DC
	Speed (Hi/Med/Low)	1000/900/870/850	1100/1000/950/900	1050/950/900/850	1100/1000/950/900	1300/1200/1100/1000	1250/1200/1050/950	
Air flow	440/380/360/350	500/440/415/380	655/610/565/525	720/645/580/560	890/805/720/645	1250/1200/1145/1085/1020/950/880		
Sound Pressure level	24~33	27~36	29~38	32~42	35~43	38~47		
Body dimension (WxHxD)	Net	864x300x200	864x300x200	972x320x215	972x320x215	972x320x215	1080x335x228	
	Packing	945x375x290	945x375x290	1060x400x310	1060x400x310	1060x400x310	1160x420x315	
Body weight	9.5/12	9.5/12	11.5/14	11.5/14	11.5/14	14.8/17.8		
Refrigerant type	R410A	R410A	R410A	R410A	R410A	R410A		
Throttle type	EXV	EXV	EXV	EXV	EXV	EXV		
Liquid pipe/Gas pipe	Φ6.35/Φ9.52	Φ6.35/Φ12.7	Φ6.35/Φ12.7	Φ6.35/Φ12.7	Φ9.52/Φ15.88	Φ9.52/Φ15.88		
Drainage water pipe (Outer diameter)	Φ20	Φ20	Φ20	Φ20	Φ20	Φ20		
Operation temperature	16~32	16~32	16~32	16~32	16~32	16~32		

Notes:
 1. Power supply: 220-240V/1N for 50Hz; 208-230V/1N for 60Hz.
 2. Cooling test condition: indoor side 27°C DB, 19°C WB outdoor side 35°C DB. Heating test condition: indoor side 20°C DB, 15°C WB outdoor side 7°C DB.
 3. Sound level: measured at a point 1 m in front of the unit outlet and 0.8 m below the unit outlet center. During actual operation, these values are normally somewhat higher as a result of ambient conditions.
 4. The above data may be changed without notice for future improvement on quality and performance.

Accessories

Plenum box	Air filter	EXV	Drain pump	AC motor	DC motor
/	Standard	Standard(built-in)	/	/	Standard

Air supply smoothly

Cross flow fan, In Cooling mode, cold air is blown from horizontal. In heating mode, warm air is blown from vertical.

2 panels can be chosen

Simple, elegant, stylish, mirror design, suitable for all kinds of decoration style.

Flexible in installation

Refrigerant pipe can be connected from 3 directions.

Hotel card function

Hotel card interface is standard, which are designed to save energy by only running appliances while guest are present in their room.

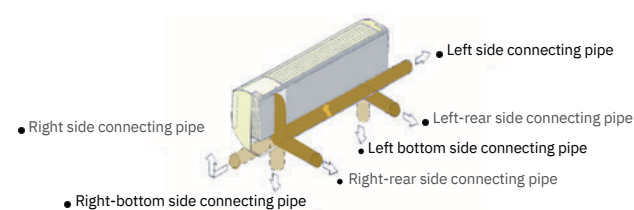

Wall Mounted Unit

FLOOR CEILING UNIT

SPECIFICATION



Accessories

Plenum box	Air filter	EXV	Drain pump	AC motor	DC motor
/	Standard	Standard(built-in)	Optional	Standard	Optional

Flexible installation

According to actual project needs, choose ceiling suspended installation or floor standing installation.



Wide angle air supply

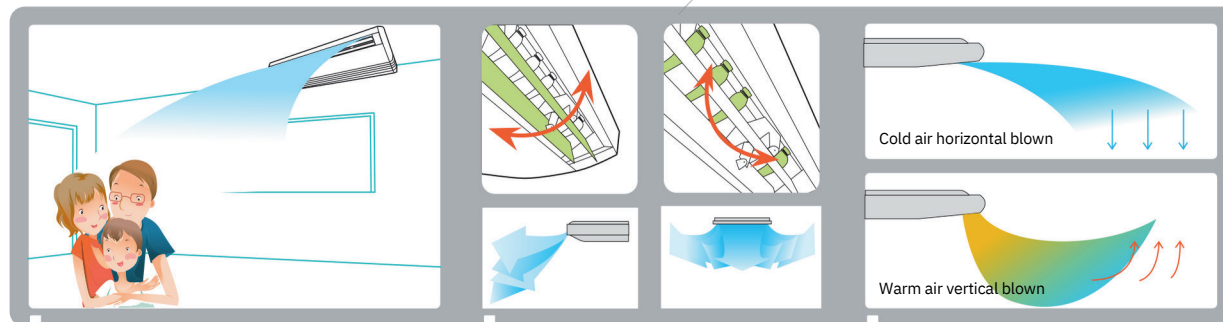

Configured with low noise high performance centrifugal fans, has big air flow and long distance air supply.

3 dimensional air supply, wide air supply angle, easily supply to every corners.

In Cooling mode, cold air is blown from horizontal. In heating mode, warm air is blown from vertical.

Easy for installation

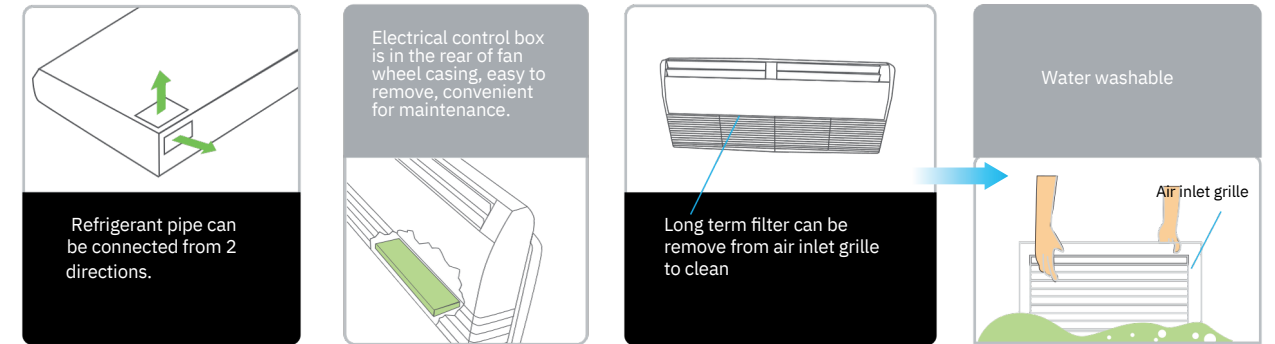

Two kinds of grilles available

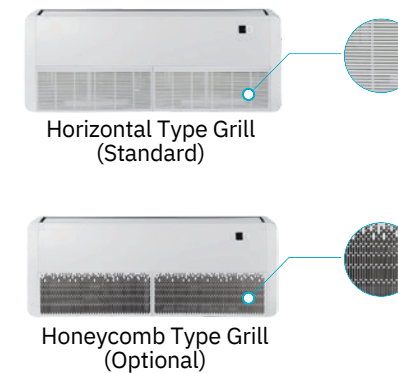

Model name	Power type	Capacity				Power input	Air flow	Sound Level	Dimension(WxHxD)		Body Weight		Connecting pipe			Standard controller	
		Cooling	Heating	Packing	Body				Net	Gross	Gas	Liquid	Drain				
		kW	kBtu/h	kW	kBtu/h	kW	M3/h	CFM	DB(A)	mmmm	mm	kg	kg	mm	mm	mm	
MCHV-V36UA/HR1-LDBA	50Hz	3.6	12.3	4.0	13.7	0.085	620	360	37-42	1130 x 765 x 330	1050 x 675 x 235	26.5	31.0	Φ12.7	Φ6.35	DN20	Remote controller
MCHV-V36UA/HNR1-LDBA	60Hz																
MCHV-V45UA/HR1-LDBA	50Hz	4.5	15.3	5.0	17	0.110	800	470	37-47	1380 x 765 x 325	1300 x 675 x 235	32.0	37.0	Φ15.88	Φ9.52	DN20	Remote controller
MCHV-V45UA/HNR1-LDBA	60Hz																
MCHV-V56UA/HR1-LDBA	50Hz	5.6	19.1	6.3	21.4	0.095	1200	706	45-51	1750 x 765 x 325	1670 x 675 x 235	41.0	47.0	Φ15.88	Φ9.52	DN20	Remote controller
MCHV-V56UA/HNR1-LDBA	60Hz																
MCHV-V71UA/HR1-LDBB	50Hz	7.1	24.2	8.0	27.2	0.160	1600	940	45-50	1750 x 765 x 325	1670 x 675 x 235	41.0	47.0	Φ15.88	Φ9.52	DN20	Remote controller
MCHV-V71UA/HNR1-LDBB	60Hz																
MCHV-V80UA/HR1-LDBB	50Hz	8.0	27.2	8.8	30	0.200	2000	1177	45-54	1750 x 765 x 325	1670 x 675 x 235	41.0	47.0	Φ15.88	Φ9.52	DN20	Remote controller
MCHV-V80UA/HNR1-LDBB	60Hz																
MCHV-V90UA/HR1-LDBC	50Hz	9.0	30.7	10.0	34.1	0.200	2000	1177	45-54	1750 x 765 x 325	1670 x 675 x 235	41.0	47.0	Φ15.88	Φ9.52	DN20	Remote controller
MCHV-V90UA/HNR1-LDBC	60Hz																
MCHV-V112UA/HR1-LDBC	50Hz	11.2	38.2	12.5	42.6	0.200	2000	1177	45-54	1750 x 765 x 325	1670 x 675 x 235	41.0	47.0	Φ15.88	Φ9.52	DN20	Remote controller
MCHV-V112UA/HNR1-LDBC	60Hz																
MCHV-V140UA/HR1-LDBC	50Hz	14.0	47.7	15.0	51.1	0.200	2000	1177	45-54	1750 x 765 x 325	1670 x 675 x 235	41.0	47.0	Φ15.88	Φ9.52	DN20	Remote controller
MCHV-V140UA/HNR1-LDBC	60Hz																
MCHV-V160UA/HR1-LDBC	50Hz	16.0	54.5	17.0	58	0.200	2000	1177	45-54	1750 x 765 x 325	1670 x 675 x 235	41.0	47.0	Φ15.88	Φ9.52	DN20	Remote controller
MCHV-V160UA/HNR1-LDBC	60Hz																

Notes:

1. Power supply: 220-240V/1N for 50Hz; 208-230V/1N for 60Hz, the above data is for AC motor model.

2. Cooling test condition: indoor side 27°C DB, 19°C WB outdoor side 35°C DB. Heating test condition: indoor side 20°C DB, 15°C WB outdoor side 7°C DB.

3. Sound level: measured at a point 1 m in front of the unit outlet and at a height of 1 m. During actual operation, these values are normally somewhat higher as a result of ambient conditions.

4. The above data may be changed without notice for future improvement on quality and performance.



Innovative air supply technology for excellent room temperature control

Fresh air unit can be connected with other type indoor units.
Layout Example:

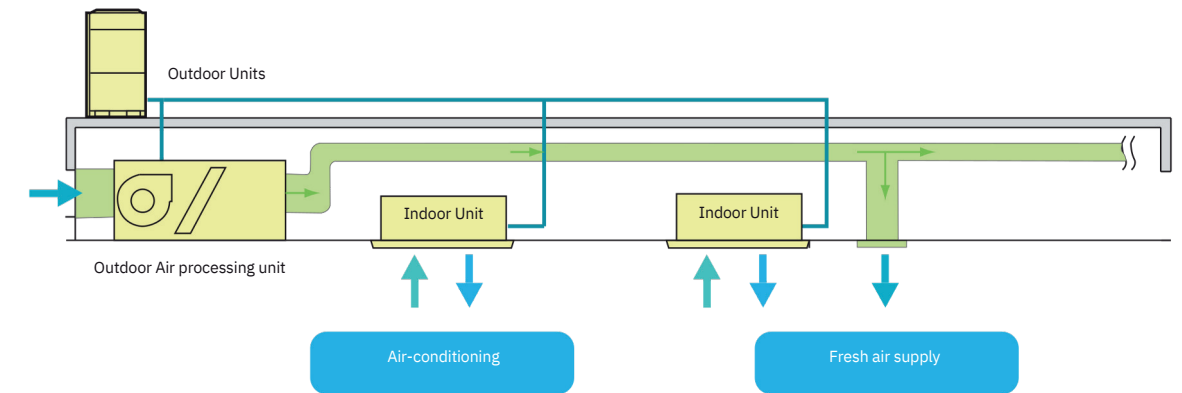

Notes: 1. When VRF system connect fresh air indoor unit and other type indoor units together, the capacity combination ratio between indoor unit and outdoor unit should within 100%
2. Fresh air unit capacity can't bigger than 30% of total indoor units capacity.

Accessories

Plenum box	Air filter	EXV	Drain pump	AC motor	DC motor
Standard	Optional	Standard	Optional	Standard	/

Healthy and comfortable environment

Fresh air is imported, provides a healthy and comfortable living environment.

Fresh air processing unit

Both fresh air filtration and heating/cooling can be achieved in a single system. Indoor units and fresh air processing unit can be connected to the same refrigerant system, increase design flexibility and greatly reduce total system costs.

High external static pressure

External static pressure can be upto 300Pa for more flexible duct applications.

Model name	Power type	Capacity				Power input	Air flow		Sound Level	ESP	Dimension(WxHxD)				Body Weight		Connecting pipe			Standard controller
		Cooling kW	Cooling kBTu/h	Heating kW	Heating kBTu/h		M3/h	CFM			Packing mm	Body mm	Panel packing mm	Panel mm	Net kg	Gross kg	Gas mm	Liquid mm	Drain mm	
MCMV-V140TF/HR1-B	50Hz	14.0	47.7	9.0	30.7	0.45	1400	820	42~48	220	1245 x 445 x 655	1190 x 370 x 620			47	51	Φ15.88	Φ9.52	ODΦ25	
MCMV-V140TF/HNR1-B	60Hz																			
MCMV-V224TF/HR1-B	50Hz	22.4	76.4	16.0	54.5	1.20	2000	1170	45~52	220	1510 x 490 x 870	1465 x 448 x 811			102	106				
MCMV-V224TF/HNR1-B	60Hz																			
MCMV-V280TF/HR1-B	50Hz	28.0	95.5	20.0	68.2	1.20	2800	1640	45~52	220	1510 x 490 x 870	1465 x 448 x 811	/	/	102	106	Φ22.2	Φ12.7	ODΦ30	Wired controller
MCMV-V280TF/HNR1-B	60Hz																			
MCMV-V450TF/HZR1	50Hz	45.0	153.5	31.4	107.1	1.60	4000	3520	58	300	2200 x 710 x 1018	2165 x 676 x 916			222	260				
MCMV-V450TF/HXR1	60Hz																			
MCMV-V560TF/HZR1	50Hz	56.0	191.0	39.0	133.0	2.50	6000	4700	62	300	2200 x 710 x 1018	2165 x 676 x 916			222	260	Φ28.6	Φ15.88	ODΦ32	
MCMV-V560TF/HXR1	60Hz																			

Notes: 1. 1.45kW & 56kW units' power supply are 380~415V/3N for 50Hz and 208~230V/3N for 60Hz, the others' power supply is 220~240V/1N for 50Hz and 208~230V/1N for 60Hz

2. Cooling test condition: Indoor and outdoor side 33°C DB, 28°C WB. Heating test condition: Indoor and outdoor side 0°CDB, -2.9°C WB.

3. Sound level: measured at a point 1 m below the unit. During actual operation, these values are normally somewhat higher as a result of ambient conditions.

4. The above data may be changed without notice for future improvement on quality and performance.

HEAT RECOVERY VENTILATOR

SPECIFICATION

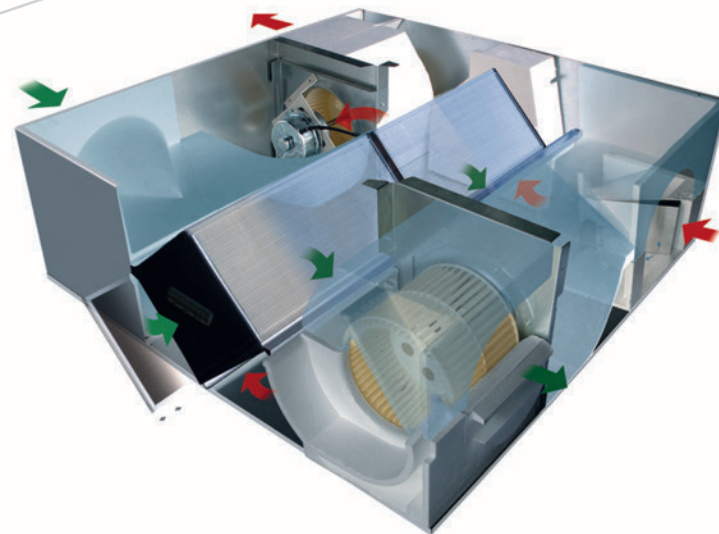
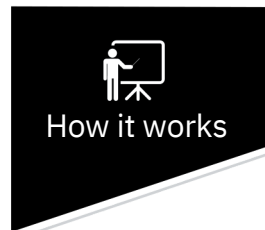
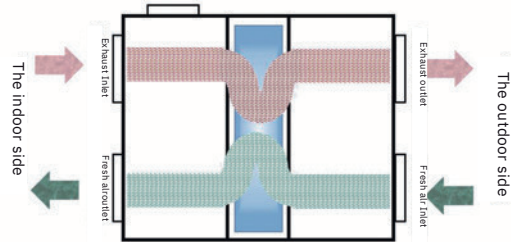

When air flow formed by exhaust air and outdoor air through the heat exchanged core in cross way, because of temperature difference in the two sides of flat partition board, the heat transmission is occurred.

In summer, outdoor air acquire cooling from air exhaust to decrease environment temperature; In winter, outdoor air acquire heating from air exhaust to increase temperature, that is to say, it realizing the energy recovery during air exhaust process to exchange the heating in heat exchanged core to outdoor air.

Application for: business office buildings, hotels, restaurants, meeting rooms, exhibition centres, leisure centres, workshop and other places.

Suspended type specification

Model name	Air flow M3/h	ESP Pa	Power input W	Power supply (V)	Temperature exchanging efficiency(%)		Enthalpy exchanging efficiency(%)		Noise dB(A)	Body dimension (WxDxH) mm	Weight kg
					Cooling	Heating	Cooling	Heating			
MQR-X02D	200	75	65	220V/1N/50Hz	60.0	65.0	50.0	55.0	30	666x580x264	25
MQR-X03D	300	75	130		60.0	65.0	50.0	55.0	33	744x599x270	27
MQR-X04D	400	80	200		60.0	65.0	50.0	55.0	35	744x804x270	30
MQR-X05D	500	80	220		60.0	65.0	50.0	55.0	38	824x904x270	41
MQR-X06D	600	90	242		60.0	65.0	50.0	55.0	40	824x904x270	42
MQR-X08D	800	100	410		60.0	65.0	50.0	55.0	42	1116x884x388	68
MQR-X10D	1000	150	510		60.0	65.0	50.0	55.0	43	1116x1134x388	82
MQR-X13D	1300	150	530		60.0	65.0	50.0	55.0	45	1116x1134x388	82
MQR-X15DS	1500	160	1000	380V/3N/50Hz	60.0	65.0	50.0	55.0	51	1600x1200x540	200
MQR-X20DS	2000	170	1200		60.0	65.0	50.0	55.0	53	1650x1400x540	225
MQR-X25DS	2500	180	2000		60.0	65.0	50.0	55.0	55	1430x1610x600	240
MQR-X30DS	3000	200	2100		60.0	65.0	50.0	55.0	57	1600x1700x640	270
MQR-X40DS	4000	220	2400		60.0	65.0	50.0	55.0	60	1330x1725x1050	265
MQR-X50DS	5000	240	3000		60.0	65.0	50.0	55.0	61	1660x1820x1050	280
MQR-X60WS	6000	290	3600		60.0	65.0	50.0	55.0	70	1660x1820x1050	310
MQR-X70WS	7000	310	4200		60.0	65.0	50.0	55.0	73	2060x1660x1168	360
MQR-X80WS	8000	320	6000		60.0	65.0	50.0	55.0	74	2060x1660x1168	382
MQR-X90WS	9000	340	7500		60.0	65.0	50.0	55.0	77	2310x1900x1200	500
MQR-X100WS	10000	400	8000	60.0	65.0	50.0	55.0	78	2310x1900x1200	534	

Notes: 1. Cooling test condition: indoor side 27°C DB, 19.5, WB; outdoor fresh air 35°C DB, 28°C;
2. Heating test condition: indoor side 21°C DB, 13, WB outdoor fresh air 5°C DB, 2°C;
3. The above data may be changed without notice for future improvement on quality and performance.

Heat Recovery Ventilator



AIR HANDLER UNIT



Insulated cabinet

Galvanized steel with paint on all panels. Thermal insulator cover all inside panels to reduce heat and cooling losses and prevent condensed water accumulation.

Motor & Blower

Direct drive motors, 3-speed, provide selections of air flow to meet desired applications. Ø10" big fan, powerful wind.

Coil

"A" shape coils, constructed with copper tubing and enhanced aluminum fins.

Filter optional

Detachable air filter for cleaning or renewal.

Multi-position installation

Versatile 4-way convertible design for vertical up airflow, horizontal right airflow.

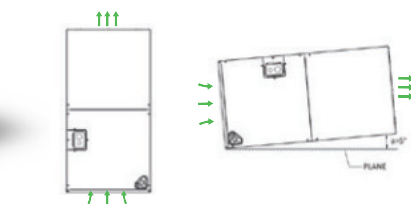

*Note: Installation of vertical up airflow and horizontal right airflow needs to be customized.

Specification

Model name	Power type	Capacity				Power input	Air flow		Sound Level	ESP	Dimension(WxHxD)		Body Weight		Connecting pipe			Standard controller
		Cooling kW	Heating kW	W	M3/h		CFM	DB(A)			Pa	Body mm	Packing mm	Net kg	Gross kg	Gas mm	Liquid mm	
MCMV-V71AH/HNR1	60Hz	7.1	24.1	8.0	27.2	290	1500	882.3	51-54	25	774x520x460	834x520x565	36	39	Ø15.88	Ø9.52	Ø20	Wired Controller
MCMV-V105AH/HNR1	60Hz	10.5	35.7	11.5	39.1	290	1500	882.3	51-54	37	774x520x460	834x520x565	36	39	Ø15.88	Ø9.52	Ø20	Wired Controller
MCMV-V160AH/HNR1	60Hz	16.0	54.4	18.0	61.2	517	2500	1470.6	57-60	50	970x550x500	1030x560x595	48	52	Ø15.88	Ø9.52	Ø20	Wired Controller

Notes: 1. Power supply: 208-230V/1N/60Hz;

2. Cooling test condition: Indoor side 27°C DB, 19°C WB, outdoor side 35°C DB. Heating test condition: Indoor side 20°C DB, 15°C WB, Outdoor side 7°C DB;

3. Sound level: measured at a point 1 m in front of the unit outlet and at a height of 1 m. During actual operation, these values are normally somewhat higher as a result of ambient conditions.

4. The above data may be changed without notice for future improvement on quality and performance.



Wireless Controllers



CONTROL SYSTEM

Wired Controllers



ZKX-C/T/A-06TW

- Bidirectional communication. Indoor unit's operating parameters(error code, temperature, address)can be inquired and displayed on the controller.
- Compact design
- Timer function
- °F/°C Fahrenheit/centigrade setting
- Address setting
- Press button tone setting

Touch Screen Wired Controller

- Air filter cleaning reminding function.
- Touch screen with black background and blue light
- Ultra thin body and stylish design meet high-end environments.
- On/off, temperature setting, fan speed setting, mode setting, timer and check function.



Simple Centralized Controller



CSP-D184

- Indoor unit operation state
- Indoor unit control order

- Easy to install. Controller connects to outdoor units only.
- 1 Controller can control max. 100 indoor units.
- Mode lock function, user can lock the running mode of indoor unit.
- Build in Modbus protocol.

Smart Manager

- Available on iOS and Android



- Remote control via cloud server



- Single unit controller or group control
- Weekly schedule management
- 100 indoor units can be controlled
- Operation parameter enquiry

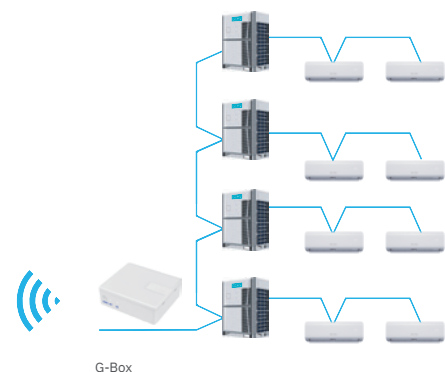

CONTROL SYSTEM

Touch Screen Centralized Controller

- Build in WIFI modular
- Build in Modbus protocol
- Weekly schedule management
- Operation parameter enquiry
- User friendly UI design

MCHV-NET(Centralized Control System)

BMS/BAS System

Gateways

Router

Controller

- Centralized control
- Electricity charge management
- Operation data record
- Schedule management

MCHV Pro VRF systems

CONTROL SYSTEM

BMS Gateway

- Modbus gateway | Independent Modbus Box or built-in with outdoor unit.
- BACnet gateway | Connect with Modbus gateway, use BACnet IP protocol.

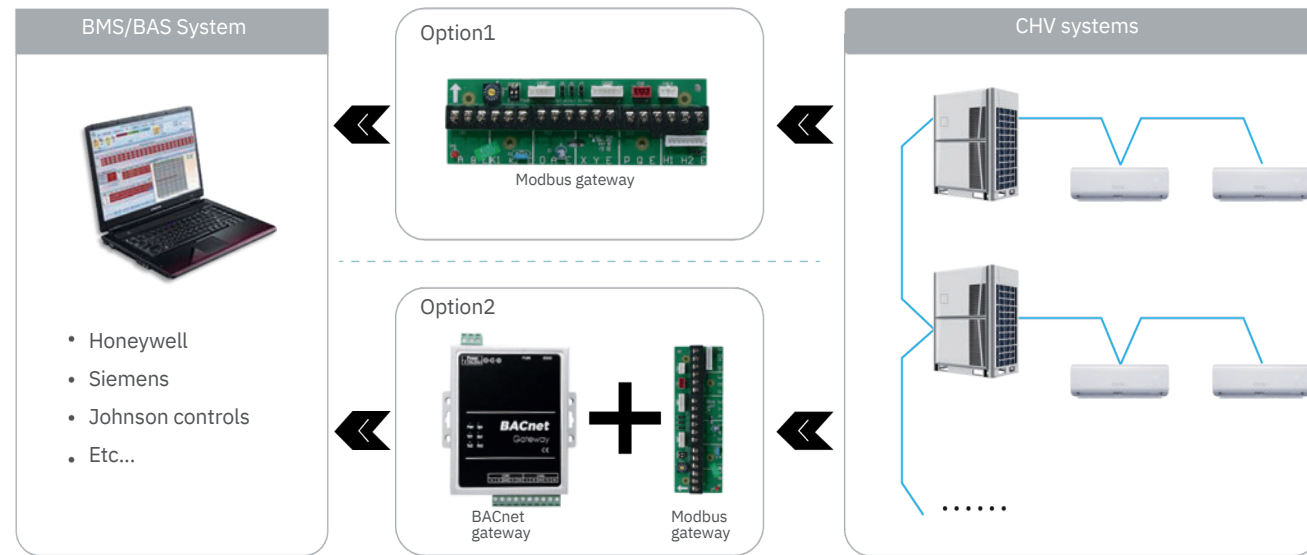

AHU Connection Kit

- MCHV AHU kit is an interface that allows 3rd party manufacturer's AHU connecting to MCHV VRF outdoor units.
- No address limit and automatic addressing.
- Split type, convenient for installation.
- One electrical part has one address and can max. connect 4 EXV parts.
- One AHU kit can max. connect up to 120HP.

MCHV AHU Kit

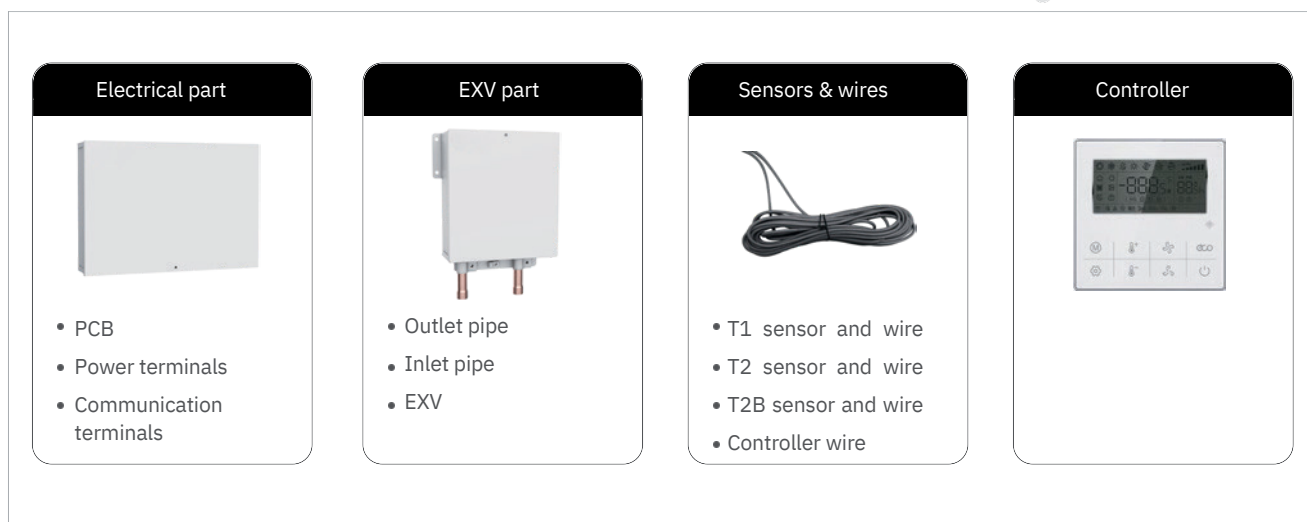

CONTROL SYSTEM

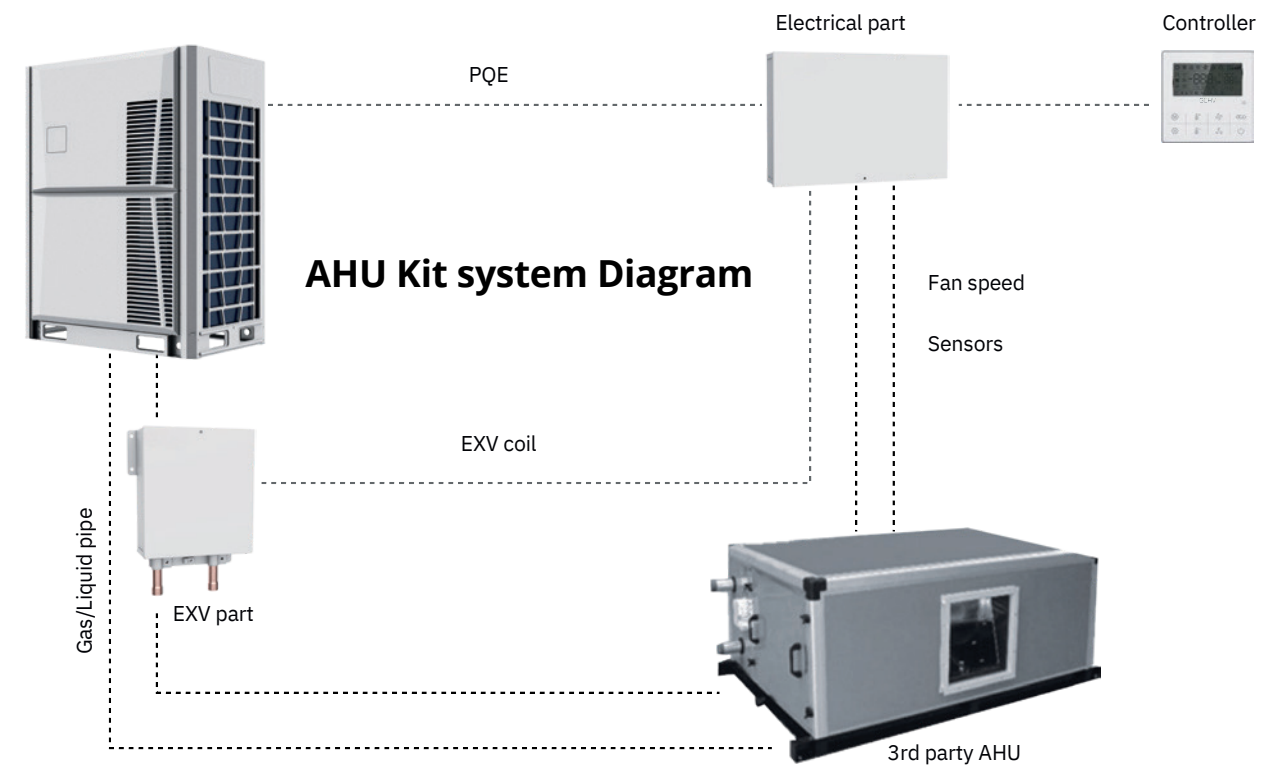

VRF Selection Software

The selection software provides a comprehensive selection of system design reports and calculations. Base on the units selected, the software produces detailed system layout and piping requirement calculations, greatly improves the work efficiency.

